

Pag. 51

Ricambi
Spare parts
Pièces détachées
Ersatzteile



HPA

B 650

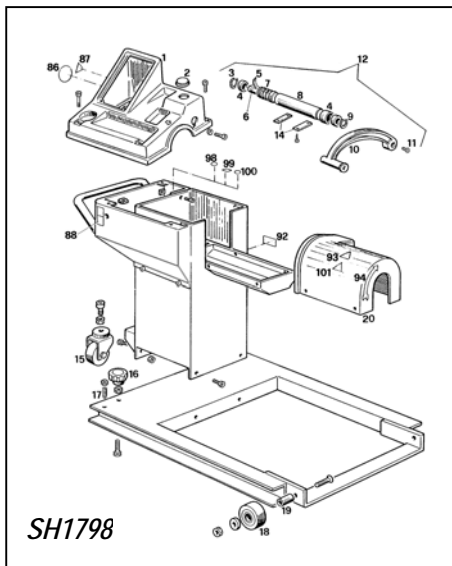

SH1798

Pag. 261
Vol. 2°

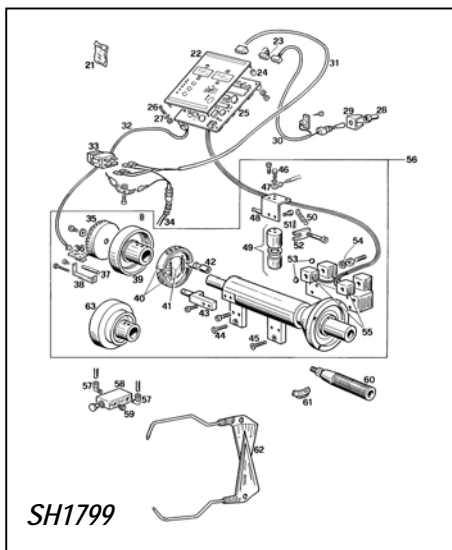

SH1799

Pag. 262
Vol. 2°

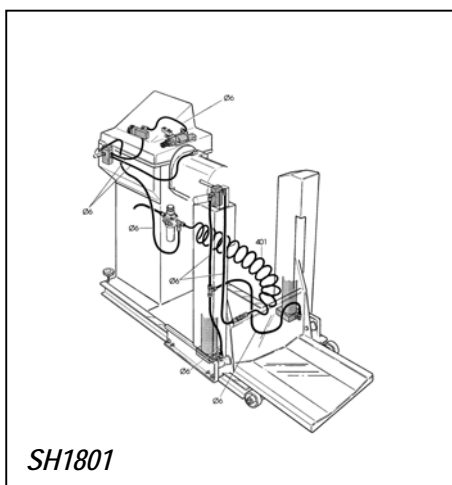

SH1801

Pag. 264
Vol. 2°

Pag. 263
Vol. 2°

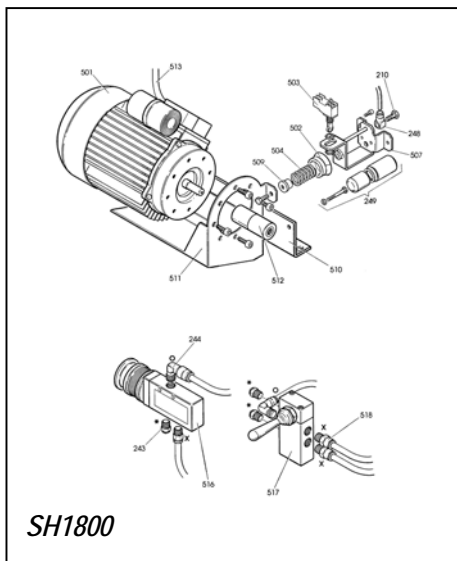

SH1800

Pag. 172
Vol. 1°

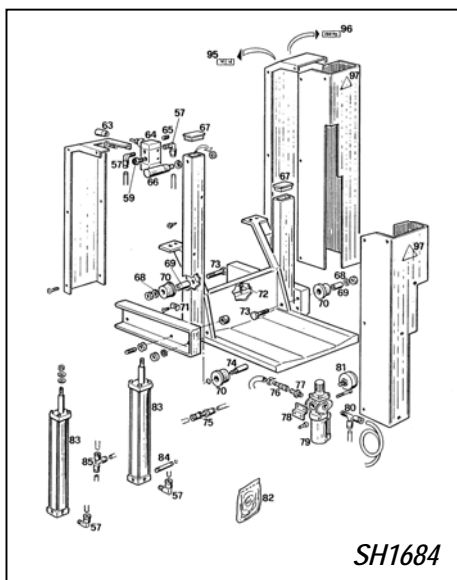

SH1684

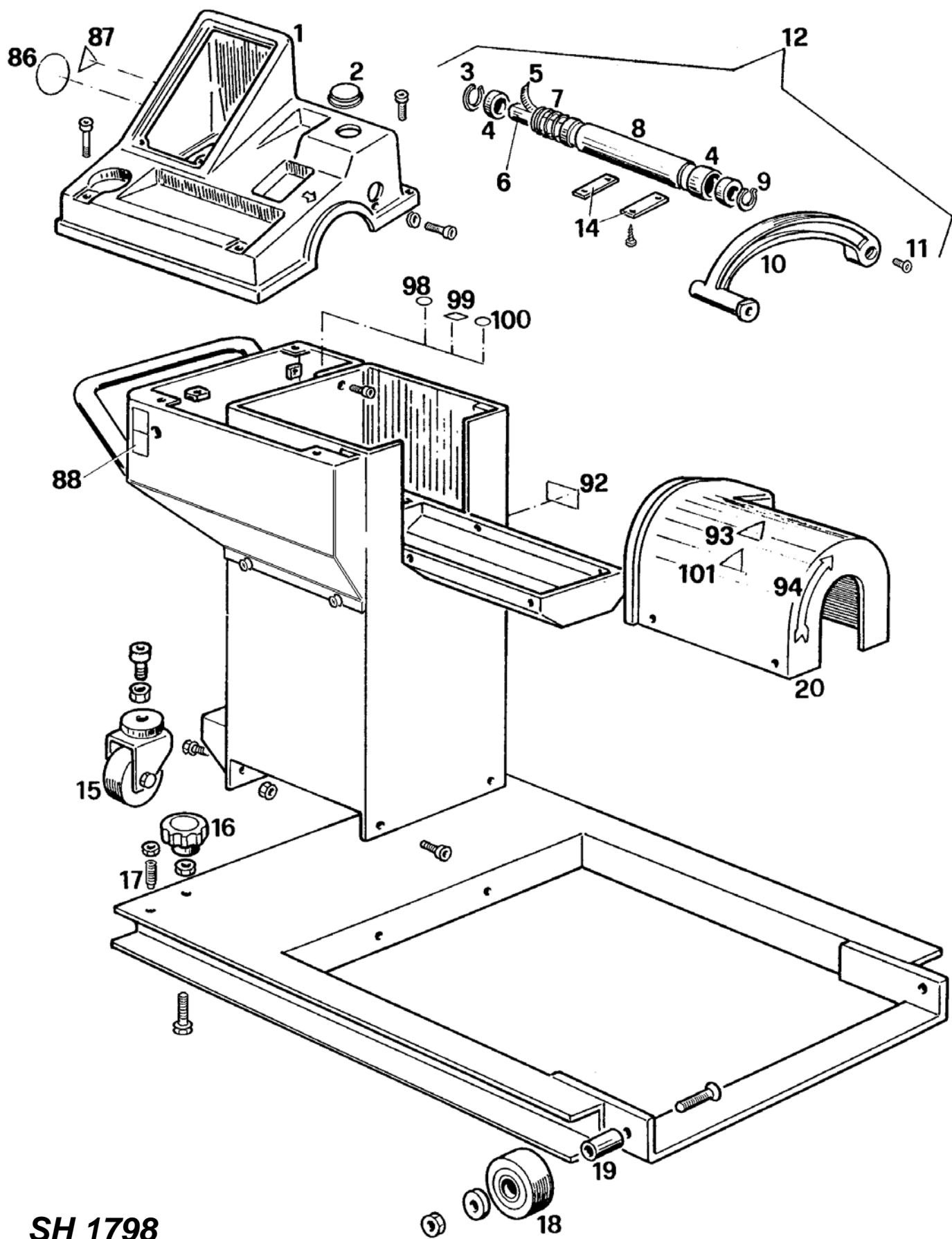

SH 1798

Codice Code	Pos.	Ricambi Descrizione	Spare parts Description	Pièces Détachées Désignation	Ersatzteile Beschreibung
443592	1	Coperchio portapesi	<i>Weight storage deck</i>	Plan porte-masses	<i>Behälter für Gewichte</i>
448000	2	Tappo HEYCO DP-1093	<i>Plug HEYCO DP-1093</i>	Bouchon HEYCO DP-1093	<i>Verschluß HEYCO DP-1093</i>
439465	3	Anello AV 18	<i>Ring AV 18</i>	Anneau AV 18	<i>Ring AV 18</i>
439461	4	Boccola	<i>Bushing</i>	Coquille	<i>Büchse</i>
439488	5	Targhetta L = 400	<i>Data plate L = 400</i>	Plaquette L = 400	<i>Typenschild L = 400</i>
344933	6	Asta rilevatore	<i>Gauge rod</i>	Tige capteur	<i>Tasterstange</i>
439460	7	Molla d. 21 x 550 x 1	<i>Spring d. 21 x 550 x 1</i>	Ressort d. 21 x 550 x 1	<i>Feder d. 21 x 550 x 1</i>
344932	8	Tubo supporto	<i>Support pipe</i>	Support tuyau	<i>Halterungsrohr</i>
439466	9	Anello JV 24	<i>Ring JV 24</i>	Anneau JV 24	<i>Ring JV 24</i>
443596	10	Leva rilevatore	<i>Gauge lever</i>	Levier capteur	<i>Tasterhebel</i>
434491	11	Vite M 6 x 20	<i>Screw M 6 x 20</i>	Vis M 6 x 20	<i>Schraube M 6 x 20</i>
244916	12	Rilevatore completo	<i>Complete gauge</i>	Détecteur complet	<i>Fühler komplett</i>
347998	14	Piastrina rilevatore	<i>Gauge plate</i>	Plaquette capteur	<i>Plättchen</i>
444946	15	Ruota d. 60 H 90	<i>Wheel d. 60 H 90</i>	Roue d. 60 H 90	<i>Rad d. 60 H 90</i>
432480	16	Manopola d. 60 M 8	<i>Knob d. 60 M 8</i>	Poignée d. 60 M 8	<i>Plastikgriff d. 60 M 8</i>
421227	17	Grano M 8 con sfera	<i>Grub screw M 8 with steel ball</i>	Cheville M 8 avec bille	<i>Stift M 8 mit Kugel</i>
344955	18	Ruota d. 60 x 35	<i>Wheel d. 60 x 35</i>	Roue d. 60 x 35	<i>Rad d. 60 x 35</i>
344957	19	Perno	<i>Pin</i>	Pivot	<i>Zapfen</i>
440244	20	Protezione gruppo oscillante	<i>Shaft assembly guard</i>	Protection pour groupe oscillant	<i>Schwenkeinheits-Schutz</i>
446598	86	Targhetta avvertimento "Scollegare macchina"	<i>"Disconnect machine" warning plate</i>	Plaquette avertissement "débrancher la machine"	<i>Hinweisschild "Stromversorgung unterbrechen"</i>
425211	87	Sigla adesiva "fulmine"	<i>"Lightning" sticker</i>	Sigle adhésif "éclair"	<i>Klebeschild "Blitz"</i>
446663	88	Targhetta comando freno ON-OFF	<i>ON-OFF brake control plate</i>	Plaquette commande frein ON-OFF	<i>Schild Bremssteuerung EIN/AUS</i>
446429	92	Targhetta pressione max. 16 Bar	<i>Max. pressure 16 Bar warning plate</i>	Plaquette avertissement press. max. 16 Bar	<i>Hinweisschild max. Druck 16 Bar</i>
446599	93	Targhetta avvertimento "Non usare il perno ..."	<i>Warning plate</i>	Plaquette avertissement	<i>Hinweisschild</i>
418135	94	Targhetta adesiva senso di rotazione	<i>Rotation direction sticker</i>	Plaquette adhésive du sens de rotation	<i>Klebeschild Drehsinn</i>
425083	98	Targhetta adesiva punto di massa	<i>Ground sticker</i>	Plaquette adhésive du point de masse	<i>Klebeschild Erdungspunkt</i>
446377	99	Targhetta massa per elettronica	<i>Electrind ground plate</i>	Plaquette masse électronique	<i>Schild Elektronik-Masse</i>
446237	100	Sigla adesiva "PE"	<i>"PE" sticker</i>	Sigle adhésif "PE"	<i>Aufkleber "PE"</i>
446497	101	Targhetta pericolo caduta ruota	<i>Danger from falling wheel plate</i>	Plaquette danger chute roue	<i>Gefahrenschild herabfallen des Rads</i>

N.B. I pezzi dentro ai riquadri sono normalmente disponibili a magazzino.

The parts in evidence are normally available from stock.

Les pièces détachées encadrées sont normalement disponibles en magasin.

Hinweis: Die umrahmten Teile sind in der Regel jederzeit lieferbar.

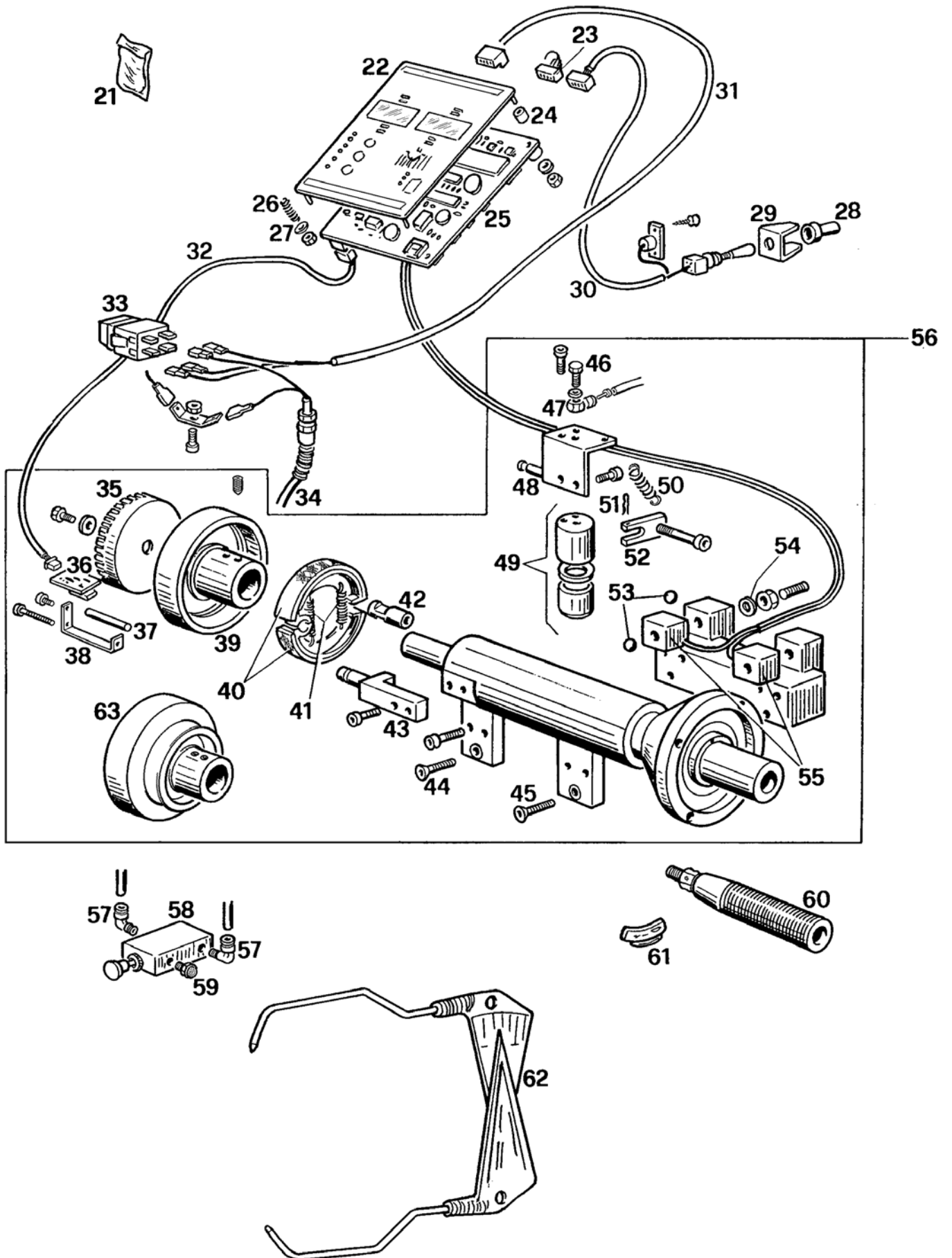

Codice Code	Pos.	Ricambi Descrizione	Spare parts Description	Pièces Détachées Désignation	Ersatzteile Beschreibung
216039	21	Sacchetto fusibili 1 A	Bag of 1 A fuses	Sachet fusibles 1 A	Säckchen mit 1 A Sicherungen
244869	21	Sacchetto fusibili 0,1 A	Bag of 0.1 A fuses	Sachet fusibles 0,1 A	Säckchen mit 0,1 A Sicherungen
484746	22	Pannello comandi	Control panel	Panneau de commandes	Steuer- und Anzeigefeld
243657	23	Connettore	Connector	Connecteur	Verbinder
438996	24	Distanziale H 9,5	Spacer H 9.5	Entretoise H 9,5	Distanzstück H 9,5
450787	25	Scheda display 220/1	Display board 220/1	Carte display 220/1	Anzeigeplatine 220/1
250810	25	Scheda display 110/1	Display board 110/1	Carte display 110/1	Anzeigeplatine 110/1
417907	26	Molla d. 6,2 x 12 x 0,6	Spring d. 6.2 x 12 x 0.6	Ressort d. 6,2 x 12 x 0,6	Feder d. 6,2 x 12 x 0,6
443597	27	Nottolino	Pawl	Cliquet	Klinke
437517	28	Cappuccio	Cap	Capuchon	Kapuze
340747	29	Protezione interruttore	Switch guard	Protection interrupteur	Schalterabdeckung
243625	30	Cavo collegamento batteria	Battery connecting cable	Câble raccordement batterie	Anschlußkabel Batterie
243612	31	Cavo alimentaz. scheda	Card power supply cord	Câble d'alimentation carte	Platinenanschlußkabel
443613	32	Cavo collegamento ricerca	Encoder board wire	Câble carte recherche	Stromzuleitung Platine
433848	33	Interruttore bipolare a bascula	Two-pole switch	Interrupteur bipolaire	Zweipolschalter
235392	34	Cavo rete	Mains supply cord	Câble réseau	Netz Kabel
423170	35	Disco ricerca	Encoder disk	Disque recherche	Suchplatte
249280	36	Gruppo ricerca	Encoder assembly	Groupe recherche	Suchgruppe
351586	37	Distanziale	Spacer	Entretoise	Distanzstück
351574	38	Supporto scheda ricerca	Encoder board support	Support carte recherche	Suchplatinenhalterung
344913	39	Ruota freno encoder	Encoder brake wheel	Roue frein	Bremsrad
439495	40	Ceppo freno	Brake block	Mâchoire de frein	Bremsbacke
439494	41	Molla per freno d. 8,8 x 46 x 2	Brake spring d. 8.8 x 46 x 2	Ressort pour frein d.8,8x46x2	Bremsfeder d. 8,8 x 46 x 2
339271	42	Blocchetto	Block	Bloc	Block
339269	43	Attacco fulcro	Fulcrum attachment	Fixation pivot	Drehpunkt-Anschluß
339430	44	Vite svasata M 8 x 20	Screw M 8 x 20	Vis M 8 x 20	Schraube M 8 x 20
339431	45	Vite svasata M 8 x 35	Screw M 8 x 35	Vis M 8 x 35	Schraube M 8 x 35
428719	46	Vite cava singola lunga M 5	Special screw M 5	Vis spécial M 5	Speziellschraube M 5
246472	47	Raccordo orientabile corto + strozzatore 0,65	Swinging union + throttle 0,65	Raccord + etrangleur 0,65	Verbindungsstück mit Drossel 0,65
239273	48	Supporto pistone	Piston support	Support pour piston	Kolbenhalter
244969	49	Cilindro	Cylinder	Vérin	Zylinder
432335	50	Molla d. 9 x 54	Spring d. 9 x 54	Ressort d. 9 x 54	Feder d. 9 x 54
439493	51	Molla a spillo d. 2	Spring d. 2	Ressort à pointe d. 2	Haarnadelfeder d. 2
241386	52	Leva freno	Brake lever	Levier frein	Hebelbremse
600243	53	Sfera SKF-RB 7,938/T205 5/16"	5/16" Steel ball SKF-RB 7,938/T205	Bille SKF-RB 7,938/T205 5/16"	Stahlkugel SKF-RB 7,938/T205 5/16"
424993	54	Molla a tazza d. 10,2 x 22 x 1,2	Belleville washer d. 10.2 x 22 x 1.2	Ressort à godet d. 10,2 x 22 x 1,2	Tellerfeder d. 10,2 x 22 x 1,2
246137	55	Coppia pick-up + cavo	Pair of pick-up + cable	Couple pick-up avec câble	Pick-up paar + Kabel
251573	56	Gruppo oscillante completo	Complete shaft assembly	Groupe oscillant complet	Maschinenwelle, komplett
438664	57	Raccordo a L 1/8" x 6	L-Union 1/8" x 6	Raccord à L 1/8" x 6	L-Anschluß 1/8" x 6
444931	58	Valvola manuale 338-910 3 vie 1/8"	3-Way hand valve 338-910 1/8"	Soupape 338-910 3 voies 1/8"	3-Wege-Ventil 338-910 1/8"
415279	59	Silenziatore 1/8"	Silencer 1/8"	Silencieux 1/8"	Schalldämpfer 1/8"
238304	60	Mozzo filettato + estraattore	Threaded hub + extractor	Moyeu fileté + extracteur	Gewindenabe + Ausziehvorrichtung
430573	61	Peso 100 gr.	100 g. weight	Poids 100 g.	Gewicht 100 g.
439516	61	Peso 300 gr.	300 g. weight	Poids 300 g.	Gewicht 300 g.
239556	62	Calibro	Caliper	Calibre	Lehre
353104	63	Puleggia DIGITRUCK MOT.	DIGITRUCK MOT. pulley	Poulie pour DIGITRUCK MOT	Riemenscheibe für DIGITRUCK MOTORIZED

N.B. I pezzi dentro ai riquadri sono normalmente disponibili a magazzino.

The parts in evidence are normally available from stock.

Les pièces détachées encadrées sont normalement disponibles en magasin.

Hinweis: Die umrahmten Teile sind in der Regel jederzeit lieferbar.

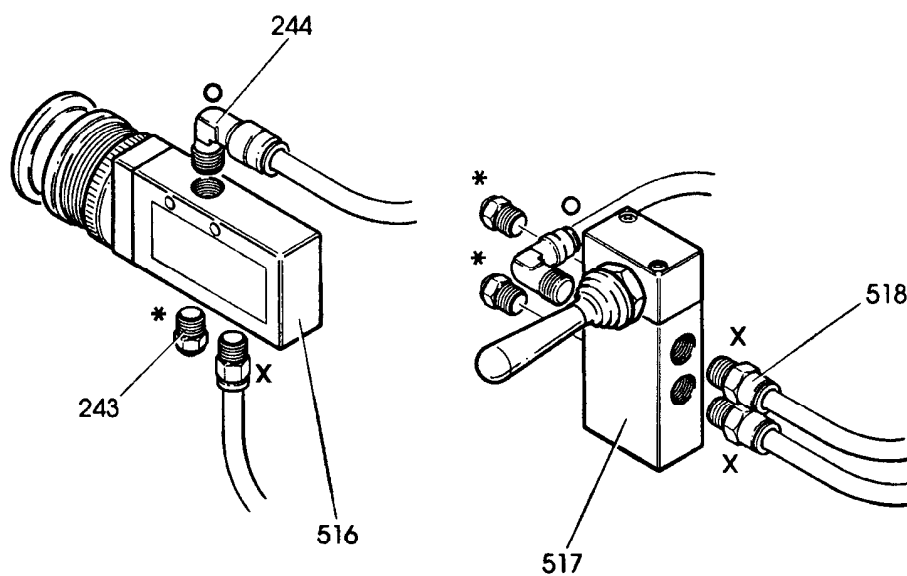
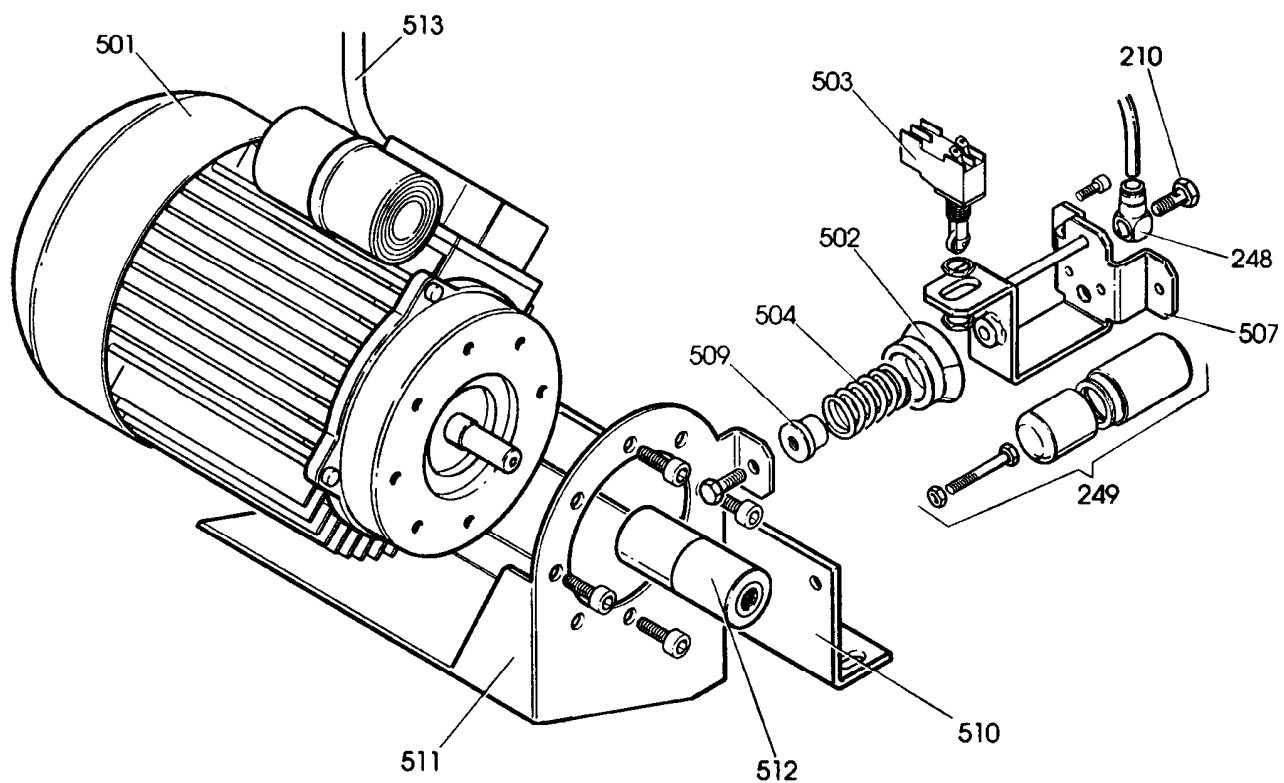

SH 1800

Codice Code	Pos.	Ricambi Descrizione	Spare parts Description	Pièces Détachées Désignation	Ersatzteile Beschreibung
428719	210	Vite cava singola M.5	<i>Special screw M.5</i>	Vis spécial M.5	<i>Speziellchraube M.5</i>
415279	243	Silenziatore 1/8"	<i>Silencer 1/8"</i>	Silencieux 1/8"	<i>Schalldämpfer 1/8"</i>
438664	244	Raccordo a L 1/8" x 6	<i>L-Union 1/8" x 6</i>	Raccord à L 1/8" x 6	<i>L-Anschluß 1/8" x 6</i>
246472	248	Raccordo orientabile corto + strozzatore 0,65	<i>Swinging union + throttle 0,65</i>	Raccord + étrangleur 0,65	<i>Verbindungsstück mit Drossel 0,65</i>
244969	249	Cilindro completo	<i>Complete cylinder</i>	Vérin complet	<i>Zylinder, kpl</i>
453035	501	Motore 0.15 KW 220 V	<i>Motor 0.15 KW 220 V</i>	Moteur 0.15 KW 220 V	<i>Motor 0.15 KW 220 V</i>
453036	501	Motore 0.15 KW 110 V	<i>Motor 0.15 KW 110 V</i>	Moteur 0.15 KW 110 V	<i>Motor 0.15 KW 110 V</i>
353111	502	Blocchetto mobile	<i>Moving block</i>	Bloc mobile	<i>Möbelblock</i>
453113	503	Microinterruttore 10A 500V	<i>Microswitch 10A 500V</i>	Microinterrupteur 10A 500V	<i>Microschalter 10A 500V</i>
453109	504	Molla	<i>Spring</i>	Ressort	<i>Feder</i>
253108	507	Supporto cilindro	<i>Cylinder support</i>	Support vérin	<i>Zylinderhalterung</i>
353112	509	Blocchetto fisso	<i>Fixed block</i>	Bloc fixe	<i>Festblock</i>
353110	510	Cerniera elastica	<i>Elastic hinge</i>	Charniere élastique	<i>Elastik-Scharner</i>
353107	511	Supporto motore	<i>Motor support</i>	Support moteur	<i>Motorhalterung</i>
253134	512	Rullo di frizione	<i>Clutch roller</i>	Rouleau de friction	<i>Walze</i>
453218	513	Cavo motore	<i>Motor cable</i>	Câble moteur	<i>Kabel</i>
453025	516	Valvola manuale 338-975 3 vie 1/8"	<i>3-Way hand valve 338-975 1/8"</i>	Soupape 338-975 3 voies 1/8"	<i>3-Wege-Ventil 338-975 1/8"</i>
453008	517	Valvola manuale 358-905 5 vie 1/8"	<i>5-Way hand valve 358-905 1/8"</i>	Soupape 358-905 5 voies 1/8"	<i>5-Wege-Ventil 358-905 1/8"</i>
441568	518	Raccordo diritto 1/8" x 6	<i>Straight union 1/8" x 6</i>	Raccord droit 1/8" x 6	<i>Hinter-Anschluß 1/8" x 6</i>

N.B. I pezzi dentro ai riquadri sono normalmente disponibili a magazzino.

The parts in evidence are normally available from stock.

Les pièces détachées encadrées sont normalement disponibles en magasin.

Hinweis: Die umrahmten Teile sind in der Regel jederzeit lieferbar.

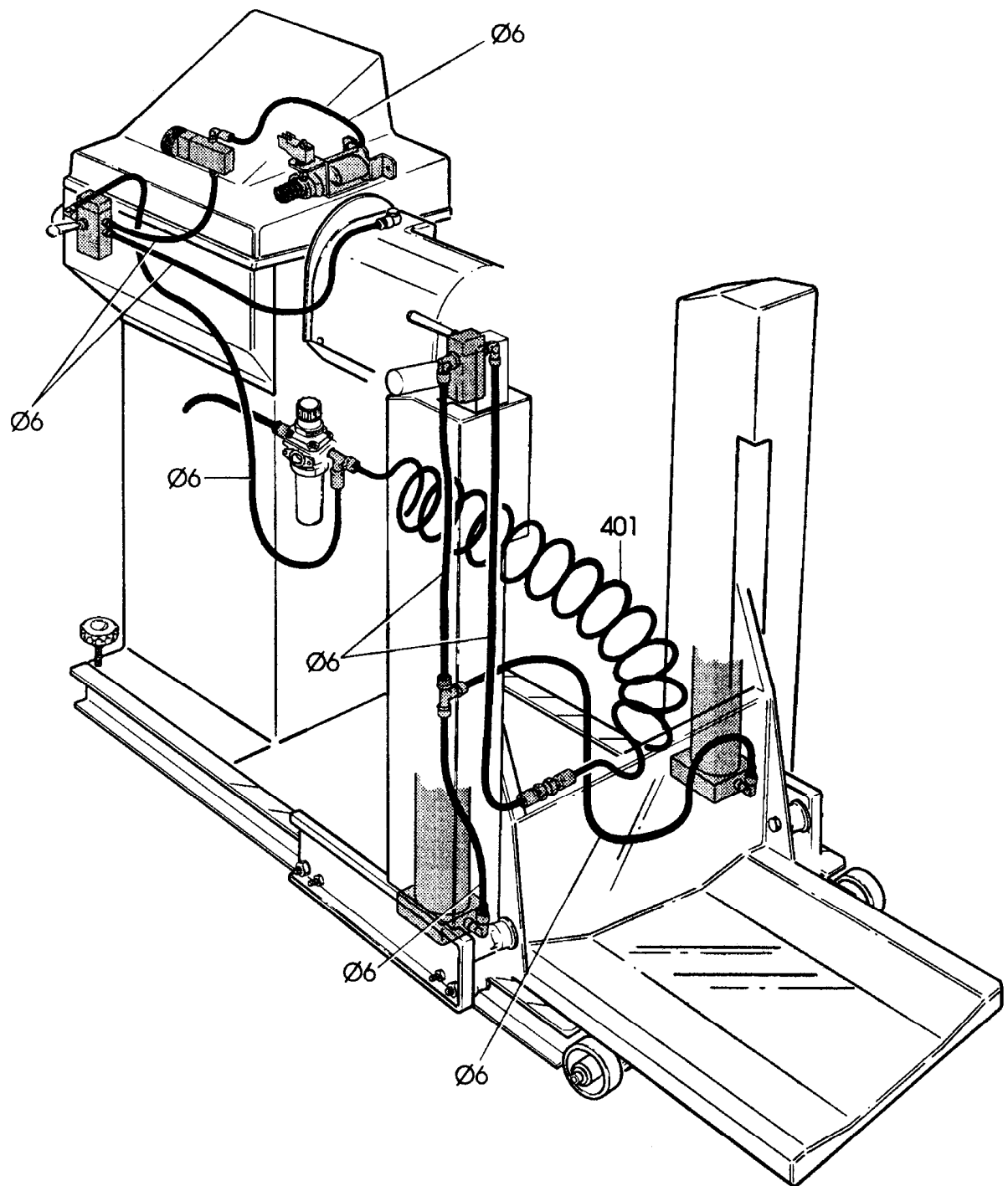

SH 1801

Codice Code	Pos.	Ricambi Descrizione	Spare parts Description	Pièces Détachées Désignation	Ersatzteile Beschreibung
701684	6	Tubo Rilsan PA 11 nero d. 6 x 1	<i>Rilsan hose PA 11 black d. 6 x 1</i>	Tuyau Rilsan PA 11 noir d. 6 x 1	<i>Rilsan Röhre PA 11 schwarz d. 6 x 1</i>
440016	90	Tubo spiralato L = 1000	<i>Spiral hose L = 1000</i>	Tube en spirale L = 1000	<i>Spiralschlauch L = 1000</i>

N.B. I pezzi dentro ai riquadri sono normalmente disponibili a magazzino.

The parts in evidence are normally available from stock.

Les pièces détachées encadrées sont normalement disponibles en magasin.

Hinweis: Die umrahmten Teile sind in der Regel jederzeit lieferbar.

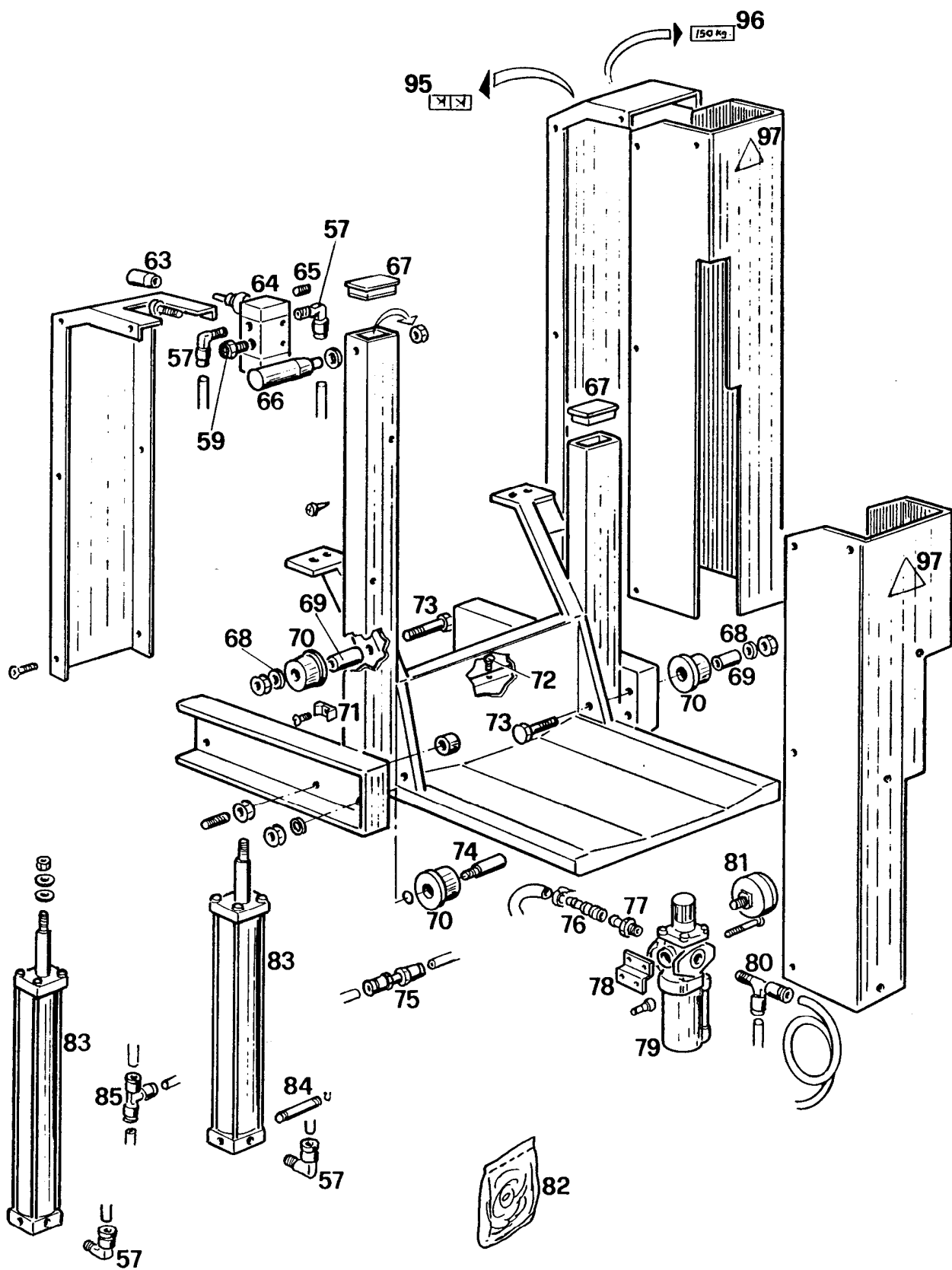

SH1684

Codice Code	Pos.	Ricambi Descrizione	Spare parts Description	Pièces Détachées Désignation	Ersatzteile Beschreibung
438664	57	Raccordo a L 1/8" x 6	L-union 1/8" x 6	Raccord à L 1/8" x 6	L-Anschluß 1/8" x 6
415279	59	Silenziatore 1/8"	Silencer 1/8"	Silencieux 1/8"	Schalldämpfer 1/8"
439238	63	Manopola	Knob	Poignée	Plastikgriff
435644	64	Valvola 1/8" 5/3 vie	5/3-Way valve 1/8"	Soupape 5/3 voies 1/8"	5/3-Wege-Ventil 1/8"
440541	65	Tappo 1/8"	Plug 1/8"	Bouchon 1/8"	Stopfen 1/8"
444342	66	Manopola girevole 1034/85/PG M10	Turning knob 1034/85/PG M 10	Bouton tournant 1034/85/PG M 10	Drehknopf 1034/85/PG M10
445031	67	Tappo GPN 270 R 50303	Plug GPN 270 R 50303	Bouchon GPN 270 R 50303	Stopfen GPN 270 R 50303
345032	68	Rondella d. 15,25 x 30 x 3	Washer d. 15.25 x 30 x 3	Rondelle d. 15,25 x 30 x 3	Scheibe d. 15,25 x 30 x 3
344998	69	Distanziale rullo	Roller spacer	Entretoise pour rouleau	Abstandstück für Rolle
244938	70	Rotella con boccia	Wheel with bushing	Roue avec douille	Rad mit Buchse
424936	71	Basetta di fissaggio	base	Petite base de fixation	Klemmenbrett
445039	72	Colonna ad espansione	Expansion column	Colonnnette à expansion	Spreizbolzen
344999	73	Perno rullo	Roller pin	Pivot pour rouleau	Zapfen für Rolle
344996	74	Perno eccentrico	Eccentric pin	Pivot excentrique	Exzenterzapfen
440013	75	Raccordo 6/4 6590-6	Union 6/4 6590-6	Raccord 6/4 6590-6	Verbindung 6/4 6590-6
441899	76	Giunto a innesto rapido femmina 1/4"	Quick release fitting, female 1/4"	Joint embrayage rapide femelle 1/4"	Aufsteck-Schnellverbinder 1/4"
441900	77	Giunto a innesto rapido maschio 1/4"	Quick release fitting, male 1/4"	Joint à embrayage rapide mâle 1/4"	Steck-Schnellverbinder 1/4"
333683	78	Staffa fissaggio filtro	Filter support bracket	Etrier de fixation du filtre	Filter-Befestigungsbügel
434617	79	Filtro regolatore	Air conditioning unit	Filtre régulateur	Regelfilter
444925	80	Raccordo rapido a T 1/4-6/4 6420	Quick T-Union 1/4-6/4 6420	Raccord rapide à T 1/4-6/4 6420	T-Schnellanschluß 1/4-6/4 6420
434818	81	Manometro d. 40 12 BAR/PSI 1/8"	Pressure gauge d. 40 12 BAR/PSI 1/8"	Manomètre d. 40 12 BAR/PSI 1/8"	Druckmesser d. 40 mit 12 BAR-Anzeigeskala 1/8"
245486	82	Kit guarnizioni	Seal kit	Kit joints	Dichtungsgarnitur
		composto da: n. 1 Anello OR d. 4,48 T 1,78 n. 2 Guarnizioni ASR 15 x 25 x 5 n. 2 Anelli OR d. 31,42 T 2,62 n. 1 Pistone CORCOS TDUOP 40-71 n. 4 Anelli OR d. 9,92 T 2,62	composed by: no. 1 O-Ring d. 4.48 T 1.78 no. 2 V-Ring ASR 15 x 25 x 5 no. 2 O-Ring d. 31.42 T 2.62 no. 1 Piston CORCOS TDUOP 40-71 no. 4 O-Ring d. 9.92 T 2.62	composition: n. 1 Bague OR d. 4,48 T 1,78 n. 2 Bagues ASR 15 x 25 x 5 n. 2 Bagues OR d. 31,42 T 2,62 n. 1 Piston CORCOS TDUOP 40-71 n. 4 Bagues OR d. 9,92 T 2,62	Bestandteile: nr. 1 O-Ring d. 4,48 T 1,78 nr. 2 Lippenring ASR 15 x 25 x 5 nr. 2 O-Ring d. 31,42 T 2,62 nr. 2 O-Ring d. 31,42 T 2,62 nr. 1 Kolben CORCOS TDUOP 40-71 nr. 4 O-Ring d. 9,92 T 2,62
244995	83	Cilindro d. 40	Cylinder d. 40	Vérin d. 40	Zylinder d. 40
344907	84	Perno cilindrico	Cylinder pin	Pivot pour cylindre	Zapfen für Zylinder
432315	85	Raccordo a T d. 6 x 1	T-union d. 6 x 1	Raccord à T d. 6 x 1	Verbindung d. 6 x 1
446667	95	Targhetta comando "UP-DOWN"	"UP-DOWN" sticker	Plaquette commande "UP-DOWN"	Aufkleber "UP-DOWN"
446668	96	Targhetta portata massima	Maximum capacity plate	Plaquette portée maximale	Schild maximale Tragkraft
446496	97	Targhetta pericolo carrello verticale	Danger sign	Plaquette danger	Gefahrenschild

N.B. I pezzi dentro ai riquadri sono normalmente disponibili a magazzino.

The parts in evidence are normally available from stock.

Les pièces détachées encadrées sont normalement disponibles en magasin.

Hinweis: Die umrahmten Teile sind in der Regel jederzeit lieferbar.