

Pag. 36

Ricambi
Spare parts
Pièces détachées
Ersatzteile



Orion

Pag. 306
Vol. 2°

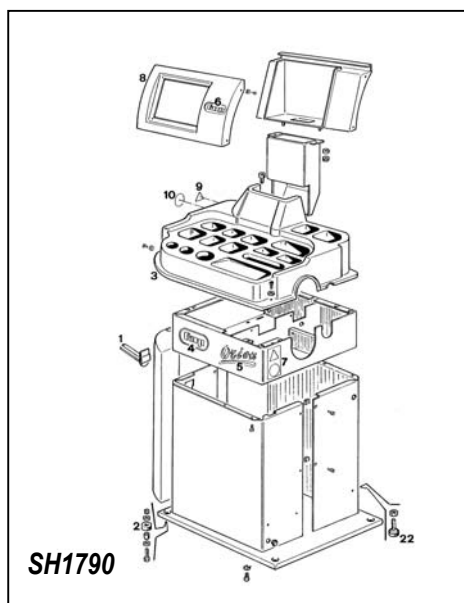

SH1790

Pag. 253
Vol. 2°

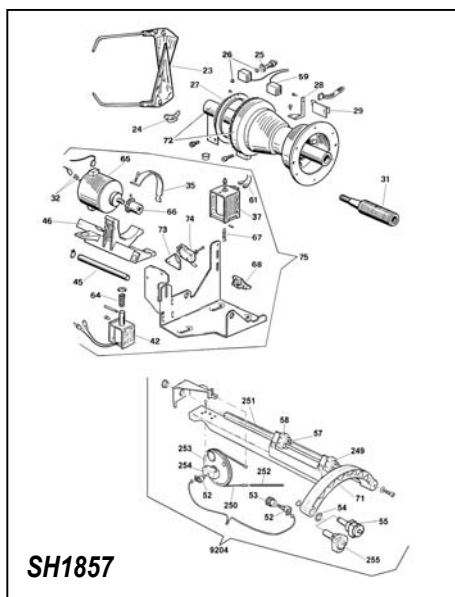

SH1857

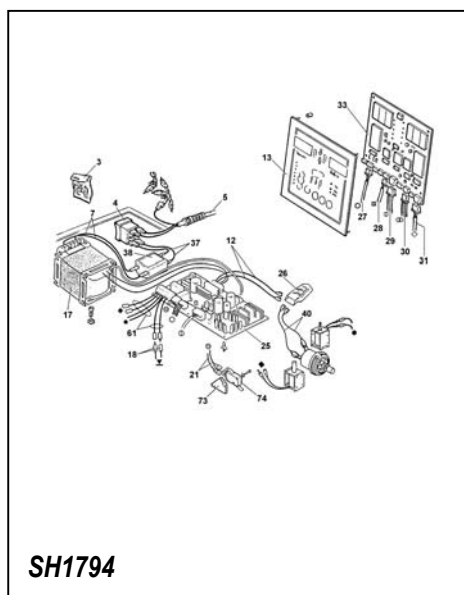

SH1794

Pag. 257
Vol. 2°

Pag. 252
Vol. 2°

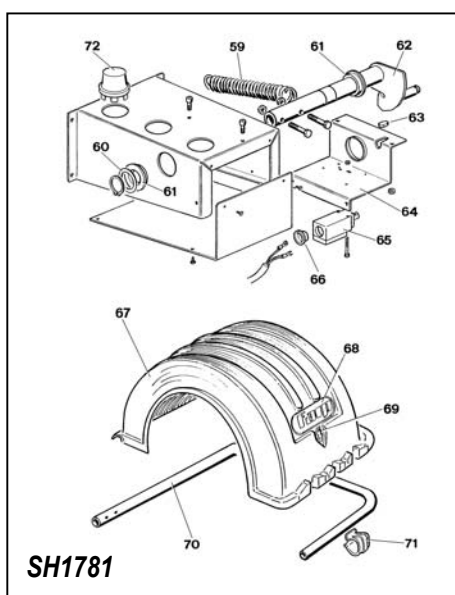

SH1781

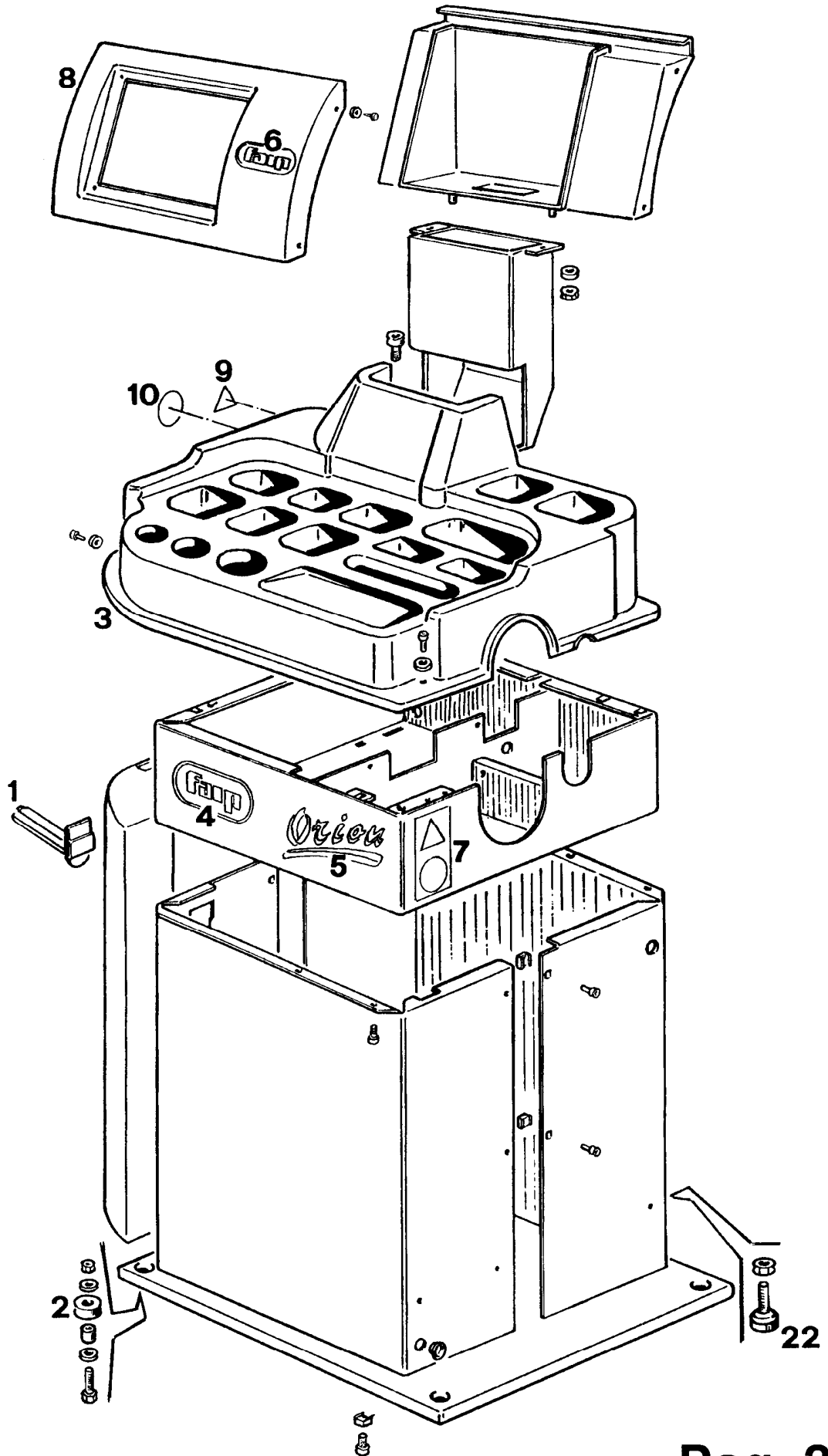

SH 1790

Codice Code	Pos.	Ricambi Descrizione	Spare parts Description	Pièces Détachées Désignation	Ersatzteile Beschreibung
438319	1	Portaflange a slitta	<i>Slide flange holder</i>	Porte-bridés coulissant	<i>Gleit-Flanschhalter</i>
427291	2	Piede	<i>Foot</i>	Pied	<i>Fuss</i>
484618	3	Coperchio portapesi	<i>Weight storage deck</i>	Plan porte-masses	<i>Behälter für gewichte</i>
479998	4	Sigla adesiva "FAIP"	<i>"FAIP" Sticker</i>	Sigle adhésif "FAIP"	<i>Aufkleber "FAIP"</i>
484651	5	Sigla adesiva "ORION"	<i>"ORION" Sticker</i>	Sigle adhésif "ORION"	<i>Aufkleber "ORION"</i>
480886	6	Sigla adesiva "FAIP"	<i>"FAIP" Sticker</i>	Sigle adhésif "FAIP"	<i>Aufkleber "FAIP"</i>
446595	7	Targhetta avvertimento "Non usare ... abbassare ... "	<i>Warning plate</i>	Plaqueette avertissement	<i>Hinweisschild</i>
484628	8	Frontale portapannello	<i>Front frame</i>	Frontal	<i>Stirnband</i>
425211	9	Sigla adesiva "fulmine"	<i>"Lightning" sticker</i>	Sigle adhésif "éclair"	<i>Klebeschild "Blitz"</i>
446598	10	Targhetta avvertimento "Scollegare macchina"	<i>"Disconnect machine" warning plate</i>	Plaqueette avertissement "débrancher la machine"	<i>Hinweisschild "Stromversorgung unterbrechen"</i>
333744	22	Puntale appoggio terra	<i>Unit resting foot on ground</i>	Pied d'appui à terre	<i>Bodenhalterung</i>

N.B. I pezzi dentro ai riquadri sono normalmente disponibili a magazzino.

The parts in evidence are normally available from stock.

Les pièces détachées encadrées sont normalement disponibles en magasin.

Hinweis: Die umrahmten Teile sind in der Regel jederzeit lieferbar.

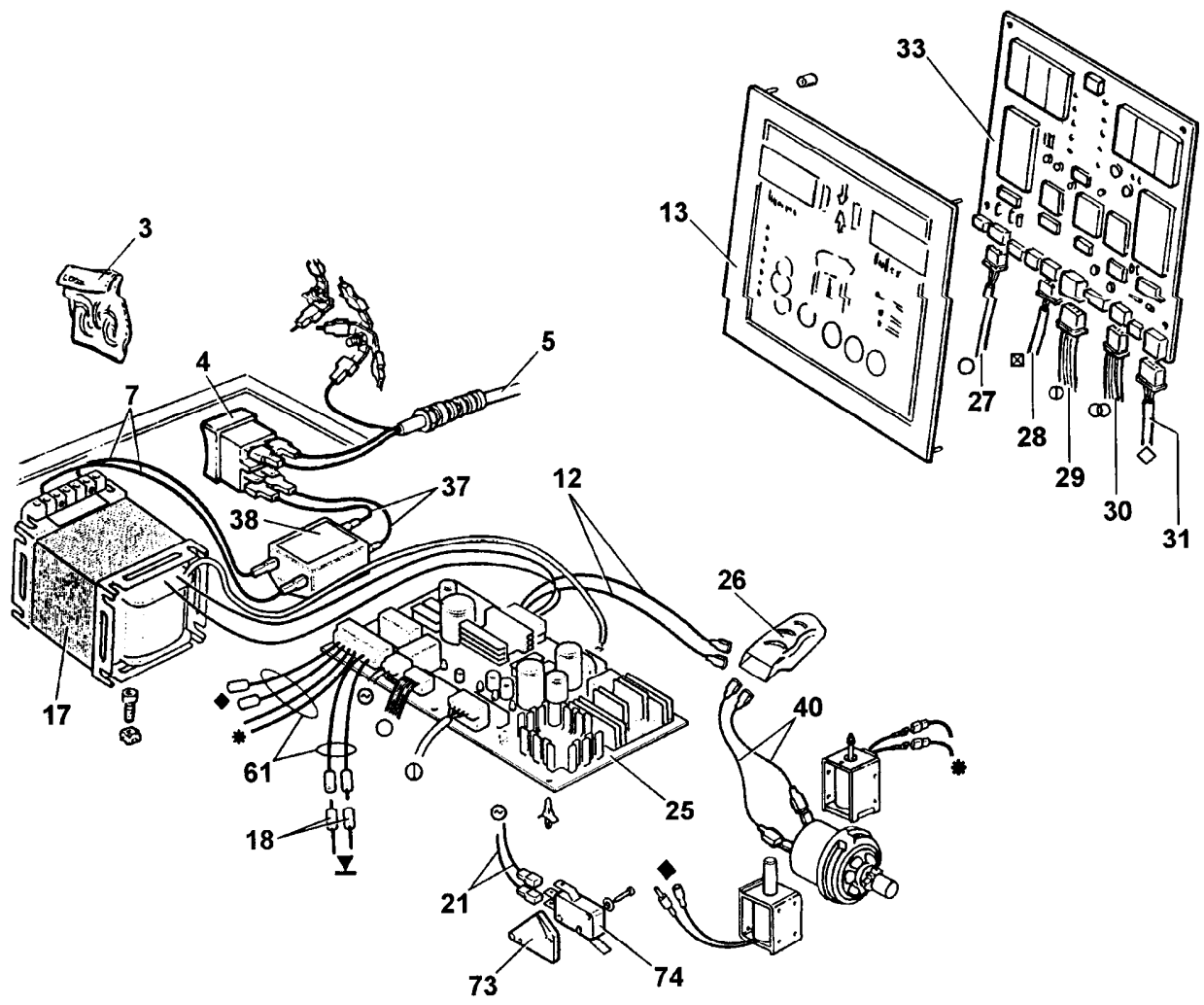

SH 1794

Codice Code	Pos.	Ricambi Descrizione	Spare parts Description	Pièces Détachées Désignation	Ersatzteile Beschreibung
218079	3	Sacchetto fusibili 3,15 A	Bag of 3.15 A fuses	Sachet fusibles 3,15 A	Beutel mit 3,15 A Sicher.
229690	3	Sacchetto fusibili 0,5 A	Bag of 0.5 A fuses	Sachet fusibles 0,5 A	Beutel mit 0,5 A Sicher.
232942	3	Sacchetto fusibili 3,15 AT	Bag of 3.15 AT fuses	Sachet fusibles 3,15 AT	Beutel mit 3,15 AT Sicher.
254977	3	Sacchetto fusibili 20 A T	Bag of 20 A T fuses	Sachet fusibles 20 A T	Beutel mit 20 A T Sicher.
433848	4	Interruttore bipolare	Two-pole switch	Interrupteur bipolaire	Zweipolschalter
235392	5	Cavo rete	Power supply cable	Câble réseau	Speisekabel
250323	7	Cavo	Cable	Cable	Kabel
249344	12	Cavo	Cable	Câble	Kabel
484476	13	Pannello comandi	Control panel plate	Panneau de commandes	Steuer-und Anzeigefeld
238727	17	Trasformatore 220 V	Power supply transf. 220 V	Transformateur 220 V	Trafo 220 V
241672	17	Trasformatore 110 V	Power supply transf. 110 V	Transformateur 110 V	Trafo 110 V
241604	18	Cavo coll.to protez. ruota	Cable	Câble	Kabel
454121	21	Cavo collegamento micro	Cable	Câble	Kabel
454218	25	Scheda alimentatore	Power board	Fiche alimentateur	Steuerplatine
454272	26	Filtro RC	RC Filter	Filtre RC	Filter RC
449318	27	Cavo flat	Flat cable	Câble flat	Flacher Kabel
449319	28	Cavo flat	Flat cable	Câble flat	Flacher Kabel
238726	29	Cavo	Cable	Câble	Kabel
449320	30	Cavo flat	Flat cable	Câble flat	Flacher Kabel
239586	31	Cavo	Cable	Câble	Kabel
254453	33	Scheda display	Display P.C. board	Fiche display	Anzeigeplatine
455684	37	Cavo	Cable	Câble	Kabel
448914	38	Filtro rete	Power supply filter	Filtre réseau	Speisefilter
454508	40	Cavo	Cable	Câble	Kabel
454657	40	Cavo	Cable	Câble	Kabel
249314	61	Cavo	Cable	Câble	Kabel
435898	73	Supporto microinterruttore	Microswitch support	Support pour microinterrup.	Lager für Mikroschalter
443611	74	Microinterruttore	Microswitch	Microinterrupteur	Mikroschalter

N.B. I pezzi dentro ai riquadri sono normalmente disponibili a magazzino.

The parts in evidence are normally available from stock.

Les pièces détachées encadrées sont normalement disponibles en magasin.

Hinweis: Die umrahmten Teile sind in der Regel jederzeit lieferbar.

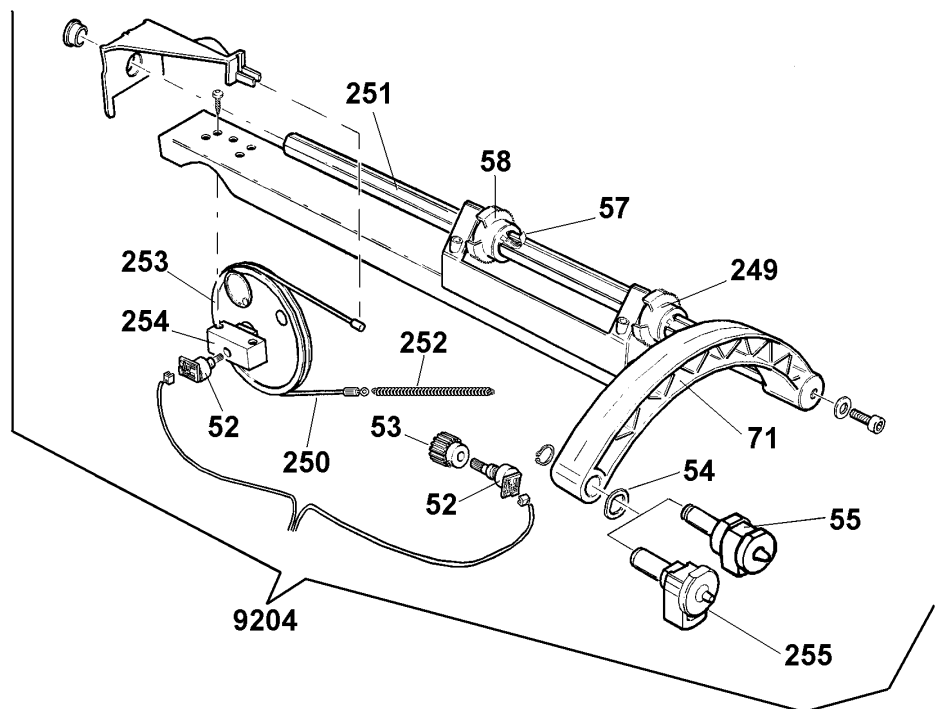
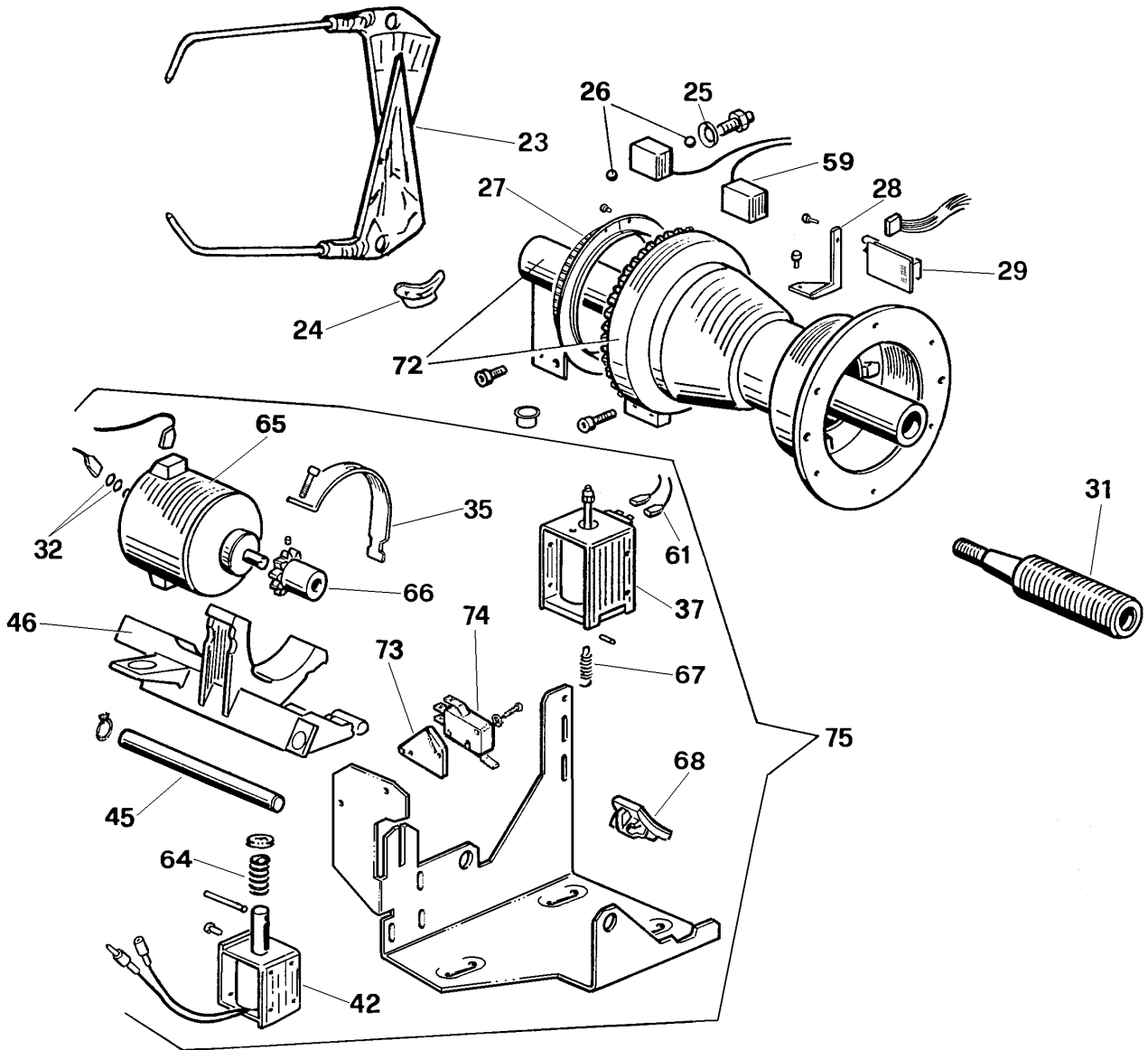

SH 1857

Codice Code	Pos.	Ricambi Descrizione	Spare parts Description	Pièces Détachées Désignation	Ersatzteile Beschreibung
223420	23	Rilevatore a compasso	Gauge	Mesureur	Aufnehmer
430573	24	Peso 100 gr.	100. Gr.weight	Poids 100 gr.	Gewicht 100 gr.
424993	25	Molla a tazza	Spring	Ressort à godet	Tellerfeder
600243	26	Sfera 5/16"	5/16" steel ball	Bille 5/16"	Stahlkugel 5/16"
449310	27	Disco ricerca	Encoder disk	Disque recherche	Suchplatte
349284	28	Supporto scheda ricerca	Encoder board support	Support carte recherche	Suchplatinenhalterung
249280	29	Gruppo scheda ricerca	Encoder board assembly	Groupe carte recherche	Suchplatine Gruppe
222099	31	Mozzo filettato + estrattore	Threaded hub + extractor	Moyeu fileté + extracteur	Gewindenabe + Ausziehvor.
417759	32	Anello OR d. 2,9 x 1,78	O-Ring d. 2.9 x 1.78	Joint torique d. 2,9 x 1.78	Dichtung OR d. 2,9 x 1,78
349358	35	Fascia bloccaggio motore	Motor band block	Bande blocage moteur	Sicherungsringmotor
250171	37	Elettromagnete	Electromagnet	Electro-aimant	Elektromagnet
249670	42	Elettromagnete	Electromagnet	Electro-aimant	Elektromagnet
349355	45	Perno	Pin	Pivot	Zapfen
349354	46	Supporto motore freno	Motor and brake support	Support moteur et frein	Halterung für Motor und Brem
248387	52	Potenziometro	Potentiometer	Potentiometre	Potentiometer
449326	53	Pignone	Pinion	Pignon	Ritzel
450073	54	Anello el. LMKAS 19 A	Ring LMKAS 19 A	Anneau LMKAS 19 A	Ring LMKAS 19 A
249339	55	Terminale	Terminal	Cosse	Endverschluss
449370	57	Targhetta L=250 mm.	Data plate L=250 mm.	Plaquette L=250	Typenschild L=250
449321	58	Boccola con corona dentata	Bushing	Douille	Buchse
243591	59	Pick-up + cavo di colleg.	Pick-up with cable	Pick-up avec câble	Pick-up mit Kabel
249314	61	Cavo	Cable	Câble	Kabel
451833	64	Molla	Spring	Ressort	Feder
450995	65	Motore	Motor	Moteur	Motor
453430	66	Pignone	Pinion	Pignon	Ritzel
454327	67	Molla	Spring	Ressort	Feder
254040	68	Pattino	Pad	Patin	Gleichschuch
449322	71	Braccio rilevatore	Gauge arm	Bras capteur	Fühler-Arm
254043	72	Gruppo oscillante	Shaft assembly	Groupe oscillant	Maschinenwelle
435898	73	Supporto microinterruttore	Microswitch support	Support pour microinterrup.	Lager für Mikroschalter
443611	74	Microinterruttore	Microswitch	Microinterrupteur	Mikroschalter
256906	75	Dispositivo di lancio	Spinning assembly	Dispositif de lancement	Meßlaufvorrichtung
454000	249	Boccola dentata di guida	Bushing	Douille	Buchse
457130	250	Fune di trascinamento	Cable	Câble	Seil
357405	251	Asta rilevatore	Sensor rod	Tige capteur	Fühler-Stab
455317	252	Molla d. 12 x 68 x 0,8	Spring d. 12 x 68 x 0,8	Ressort d. 12 x 68 x 0,8	Feder d. 12 x 68 x 0,8
457403	253	Puleggia di trascinamento	Pulley	Poulie	Riemenscheibe
357383	254	Perno forato per puleggia	Pin	Pivot	Zapfen
255046	255	Terminale GERMANIA			Endverschluss "DEUTSCHL."
257401	9204	Gruppo rilevatore STD	Gauge assembly	Groupe capteur	Aufnehmer-Gruppe
257400	9204	Gr. rilevatore GERMANIA			Aufnehmer-Gruppe "DEUT."

N.B. I pezzi dentro ai riquadri sono normalmente disponibili a magazzino.

The parts in evidence are normally available from stock.

Les pièces détachées encadrées sont normalement disponibles en magasin.

Hinweis: Die umrahmten Teile sind in der Regel jederzeit lieferbar.

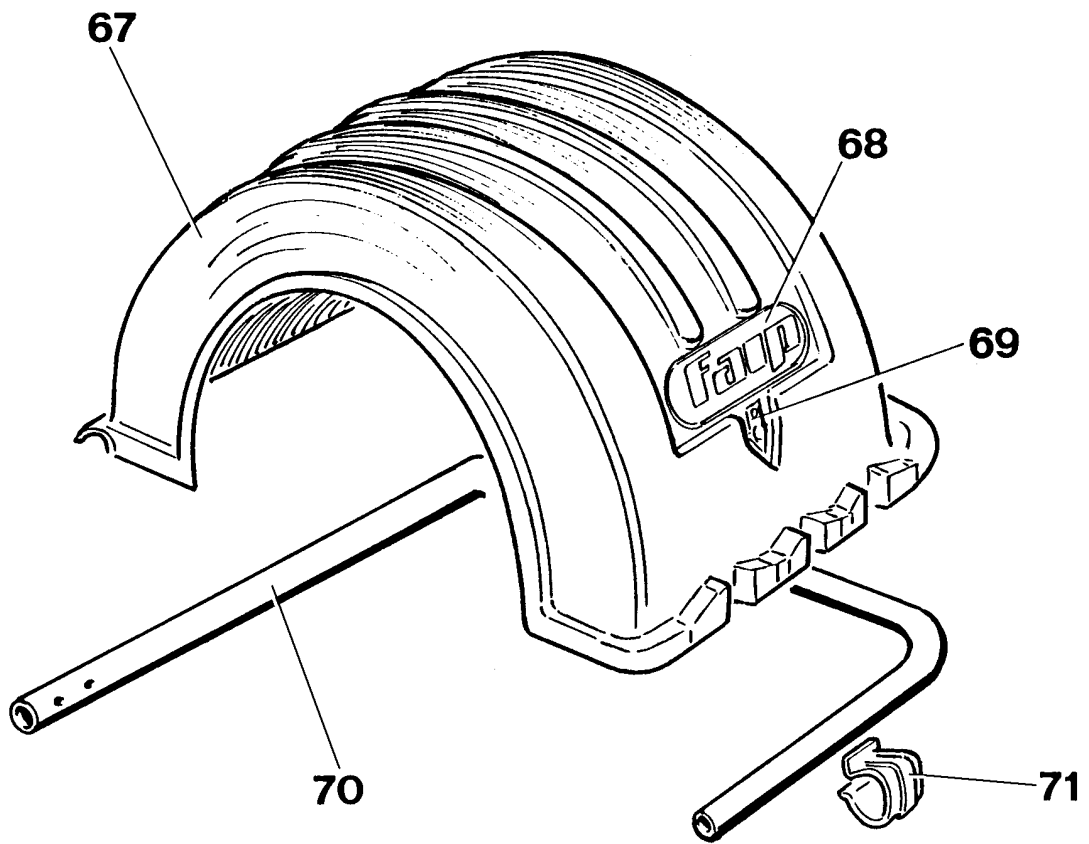
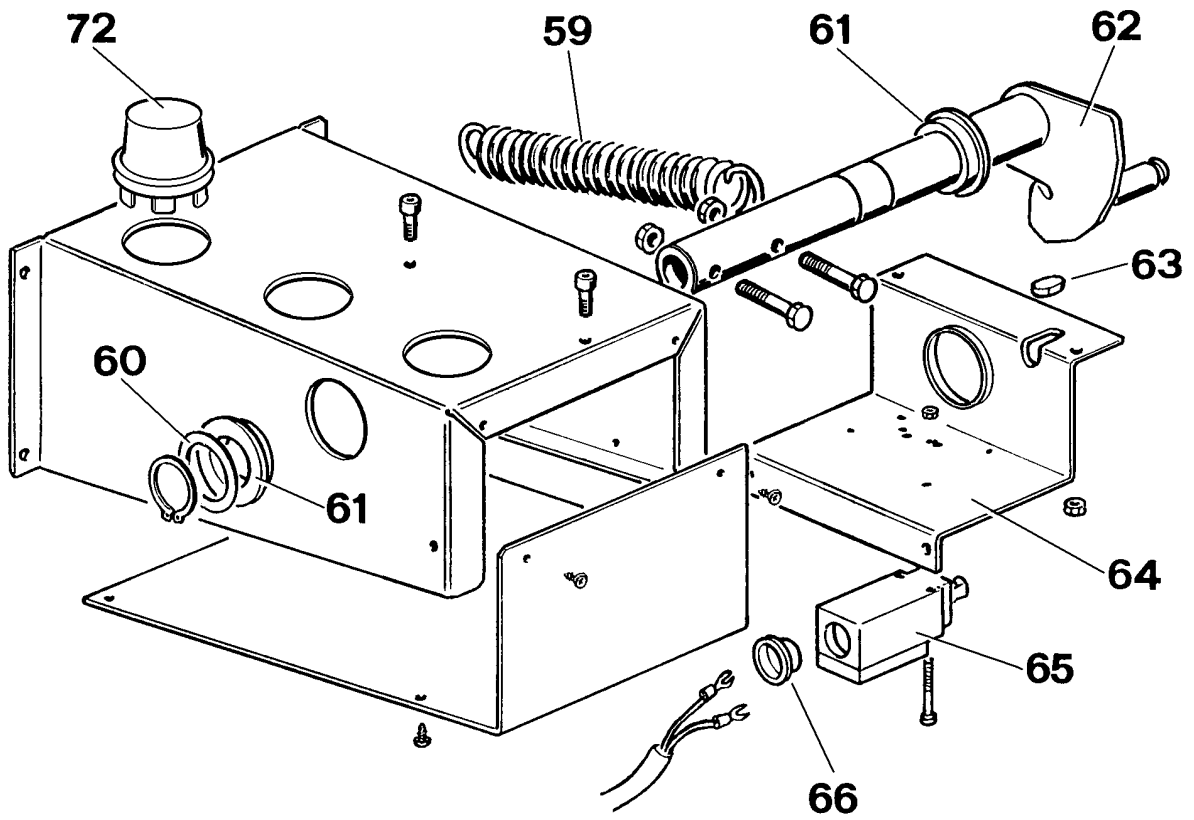

SH1781

Codice Code	Pos.	Ricambi Descrizione	Spare parts Description	Pièces Détachées Désignation	Ersatzteile Beschreibung
449270	59	Molla d. 4 x 28 x 150	<i>Spring d. 4 x 28 x 150</i>	Ressort d. 4 x 28 x 150	<i>Feder d. 4 x 28 x 150</i>
436721	60	Rondella	<i>Washer</i>	Rondelle	<i>Scheibe</i>
433637	61	Boccola per protezione	<i>Wheel guard bushing</i>	Bague pour protection	<i>Sicherheitsbuchse</i>
249267	62	Fermo protezione	<i>Wheel guard stop</i>	Arrêt protection	<i>Radschutz-Feststellvorricht.</i>
413163	63	Tassello	<i>Block</i>	Tampon	<i>Einsatzstück</i>
338723	64	Supporto protezione	<i>Guard bearing</i>	Support protection	<i>Meßvorrichtung-Halterung</i>
441494	65	Microinterruttore	<i>Microswitch</i>	Microcontact	<i>Mikroschalter</i>
431972	66	Tappo	<i>Plug</i>	Bouchon	<i>Stopfen</i>
484696	67	Protezione ruota	<i>Wheel guard</i>	Protection roue	<i>Radschutz</i>
472118	68	Sigla adesiva "FAIP"	<i>"FAIP" sticker</i>	Sigle adhésif "FAIP"	<i>Aufkleber "FAIP"</i>
483471	69	Freccia adesiva partenza automatica	<i>Automatic start sticker</i>	Plaqueette lancement automatique	<i>Aufkleber für Automatikstart</i>
349272	70	Telaio per protezione	<i>Wheel guard frame</i>	Cadre pour protection	<i>Rahmen für Radschutz</i>
449273	71	Molla	<i>Spring</i>	Ressort	<i>Feder</i>
441224	72	Portaconi ad incastro	<i>Cones support</i>	Porte-cône à encastrement	<i>Konushalter, einspannbar</i>

N.B. I pezzi dentro ai riquadri sono normalmente disponibili a magazzino.

The parts in evidence are normally available from stock.

Les pièces détachées encadrées sont normalement disponibles en magasin.

Hinweis: Die umrahmten Teile sind in der Regel jederzeit lieferbar.