

## 44012LR

### optional accessories:

#### Part#: 10267



#### Part#: 10342



#### Part#: 10310

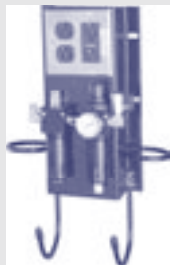

### 44012 accessories:

Part #	Description
10267	Oil drain pan kit, adj. width, 32 gallon
10342	Hanging tool holder for oil drain pan 10267
10310	Air/electric workstation with filter/lubricator/regulator
44RK12	Drive-thru ramp kit, 28" long

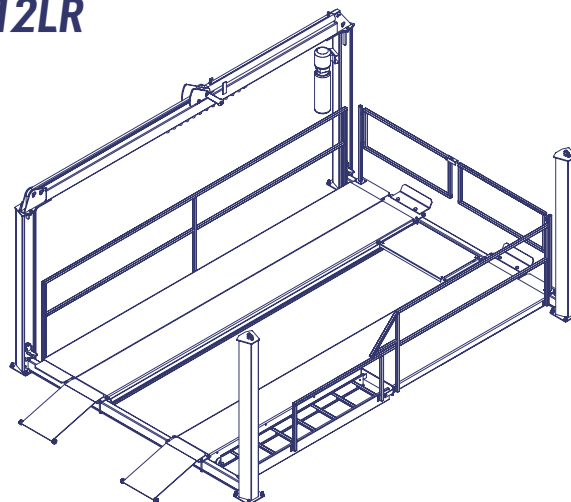

Model Number	44012LR
Lift Capacity	12,000 lb.
Maximum Wheelbase	216"
Rise Height	77 <sup>3</sup> / <sub>4</sub> "
Overall Length	22' 6 <sup>1</sup> / <sub>4</sub> "
Overall Width	12' 4 <sup>1</sup> / <sub>4</sub> "
Overall Height	100 <sup>1</sup> / <sub>2</sub> "
Inside of Columns	133"
Between Columns	221"
Height of Columns	84 <sup>3</sup> / <sub>4</sub> "
Width of Runways	20 <sup>1</sup> / <sub>2</sub> "
Height of Runways	6 <sup>3</sup> / <sub>4</sub> "
Width Between Runways	42 <sup>1</sup> / <sub>2</sub> "
Motor	2HP
Voltage - Single Phase	208v - 230v
Speed of Rise	80 sec.
Min. Recommended Bay Size	15' 6" x 25'

### Teamwork

Challenger Lifts 44012LR is the best choice for a two person oil change operation. This Lube Rack is optimized for speed and efficiency. Its design allows one person to check fluids under the hood while standing on the diamond plated catwalk and another underneath, to change filters and fluids.

With optional drive thru ramps and oil drain pan, the 44012LR is a perfect supplement to any service facility.

### Features:

- Walkways and handrails provide safety and security allowing 2 people to work on oil changes
- Front gate and moving ladder with wheels provide convenience and drive-thru flexibility
- Optional 32 gallon oil drain pan's high capacity decreases down time increasing productivity

Challenger Lifts, Inc.  
200 Cabel Street  
Louisville, KY 40206

toll free: 800.648.5438  
phone: 502.625.0700  
fax: 502.625.0711

[www.challengerlifts.com](http://www.challengerlifts.com)



Challenger Lifts, Inc. reserves the right to make changes without notice and without making changes retroactive. Unloading, installation and oil not included.

## 44012DLR

### optional accessories:

Part#: 10267

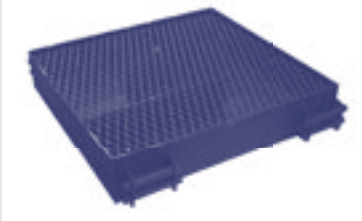

Part#: 10342



Part#: 10310

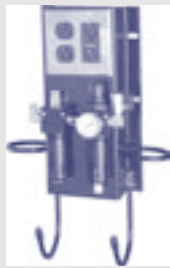

### 44012 accessories:

Part #	Description
10267	Oil drain pan kit, adj. width, 32 gallon
10342	Hanging tool holder for oil drain pan 10267
10310	Air/electric workstation with filter/lubricator/regulator
44RK12	Drive-thru ramp kit, 28" long

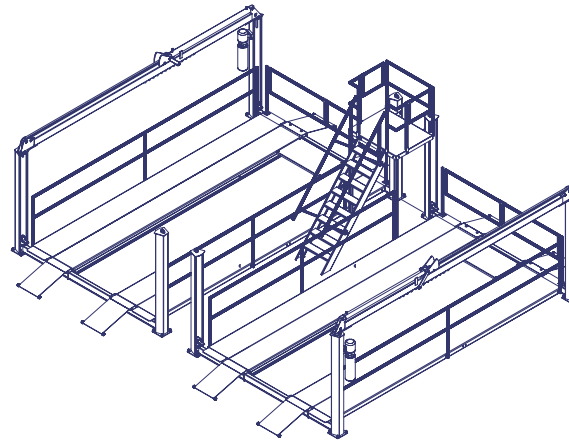

Model Number	44012DLR
Lift Capacity	12,000 lb.
Maximum Wheelbase	216"
Rise Height	77 <sup>3</sup> / <sub>4</sub> "
Overall Length	22' <sup>3</sup> / <sub>4</sub> "
Overall Width	26' 9"
Overall Height	144 <sup>1</sup> / <sub>2</sub> "
Inside of Columns	133"
Between Columns	221"
Height of Columns	84 <sup>3</sup> / <sub>4</sub> "
Width of Runways	20 <sup>1</sup> / <sub>2</sub> "
Height of Runways	6 <sup>3</sup> / <sub>4</sub> "
Width Between Runways	42 <sup>1</sup> / <sub>2</sub> "
Motor	2HP
Voltage - Single Phase	208v - 230v
Speed of Rise	80 sec.
Min. Recommended Bay Size	30' x 24' 6"

### Teamwork

Challenger Lifts 44012LR is the best choice for a two person oil change operation. This Lube Rack is optimized for speed and efficiency. Its design allows one person to check fluids under the hood while standing on the diamond plated catwalk and another underneath, to change filters and fluids.

With optional drive thru ramps and oil drain pan, the 44012LR is a perfect supplement to any service facility.

### Features:

- Walkways and handrails provide safety and security allowing 2 people to work on oil changes
- Front gate and moving ladder with wheels provide convenience and drive-thru flexibility
- Optional 32 gallon oil drain pan's high capacity decreases down time increasing productivity

Challenger Lifts, Inc.  
200 Cabel Street  
Louisville, KY 40206

toll free: 800.648.5438  
phone: 502.625.0700  
fax: 502.625.0711

[www.challengerlifts.com](http://www.challengerlifts.com)



Challenger Lifts, Inc. reserves the right to make changes without notice and without making changes retroactive. Unloading, installation and oil not included.