

CL Challenger Lifts



Model#: E10
Versymmetric® 2-Post Lift
Asymmetric application
10,000 lb. capacity

E10



E10:
3-stage front arms

Versymmetric®
Technology

The E10 features Challenger's innovative Versymmetric® Technology, providing technicians the versatility to lift vehicles both symmetrically and asymmetrically within the same service bay. This exclusive technology facilitates increased efficiency and revenue potential. With double telescoping screw pads, durable powder coat finish, plated arm restraints and pins and many other appealing features, the E10 will accommodate the rigorous demands of a full service facility – and afford room to grow with its competitive price. Available in red and blue.

Features & Benefits:

- Versymmetric® 3-stage front arms provide greater overall arm sweep for:
 - » Asymmetric or Symmetric lifting in the same service bay
 - » Uni-body design vehicles
 - » Vehicles with designated outside pick up points
 - » Wider vehicles
 - » Low profile vehicles
 - » Both short and long wheelbases
- 11' 11-7/8" reduced standard height allows lift to be placed in service bay with 12' ceiling
- Double Telescoping Screw Pads adjust to multiple heights minimizing the need for adapters
- Rubber foot pads minimize stress to vehicles with delicate undercoatings
- Padded overhead shut off system prevents vehicle damage
- Single-point mechanical lock release system allows technician to disengage both columns simultaneously
- Rubber door guards protect vehicle from door damage
- Premium powder coat finish provides long-lasting durability
- Plated Arm Restraints and Arm Pins inhibit rust and provide long-lasting durability

Economy Price

Great features and an even better price. E10 is manufactured to the highest Challenger standards and is ALI/ETL certified. Challenger Lifts' E10 is designed for long-lasting dependable service with a budget service center in mind.

For more information, contact your Authorized Challenger Lifts Distributor:

E10	Specifications
Lifting Capacity*	10,000 lb. (4536kg)
A Rise Height ¹	75 ³ / ₄ " (1924mm)
B Column Height	11' 11 ⁷ / ₈ " (3655mm)
C Overall Width	10' 11 ³ / ₄ " (3347mm)
D Drive-thru Clearance	98 ³ / ₈ " (2499mm)
E Floor to Overhead Switch	11' 5" (3482mm)
F Front Arm Reach	21 ³ / ₄ " - 39 ¹ / ₄ " (553-998mm)
G Rear Arm Reach	38 ¹ / ₄ " - 55 ³ / ₈ " (971-1407mm)
H Screw Pad Height ²	Adj. 4" - 7 ¹ / ₂ " (103mm - 194mm)
I Inside of Columns	110 ¹ / ₄ " (2800mm)
Ceiling Height Required ³	12' (3658mm)
Motor	2HP, Single Phase, 60Hz
Voltage	208 - 230v
Speed of Rise	50 seconds
Max. Load Per Arm	2,500 lb. (1134kg)

*Lift capacity ratings are based on loads equally distributed on all four arms.

- 1 Rise height measured with telescoping screw pad in highest position
- 2 Specifications are listed without rubber pad, for measurements with rubber pad add 1/4" (6mm).
- 3 Ceiling height requirement may exceed 12' if column shimming is necessary.

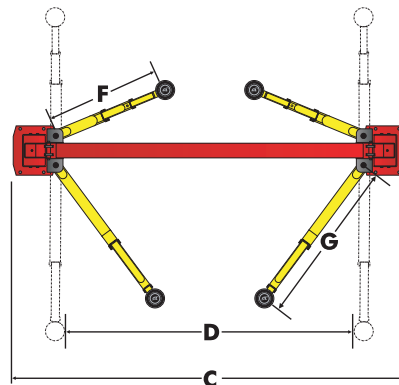
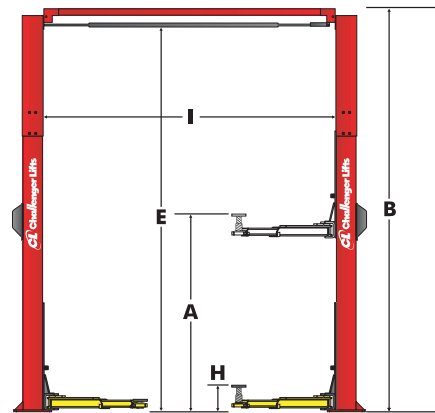

AAIA
Automotive Aftermarket
Industry Association



EGSA
Professional Service
Contract No. GS-GTF-89500

The Automotive Lift Institute (ALI) certifies that the E10 described herein complies with the applicable provisions of the American National Standards ANSI/ALI ALCTV 2006 and is Third Party Validated by the ETL Testing Laboratory.

CHALLENGER LIFTS, INC.
200 Cabel Street
Louisville, Kentucky 40206

Phone Toll-Free: 800-648-5438
502-625-0700
Fax: 502-625-0711
E-mail: sales@challengerylifts.com

Challenger Lifts, Inc. reserves the right to make changes to specifications without notice and without making changes retroactive. Unloading, installation and oil not included.