

Pag. 45

Ricambi
Spare parts
Pièces détachées
Ersatzteile



**VIDEOTRUCK
2002**



SH 1913

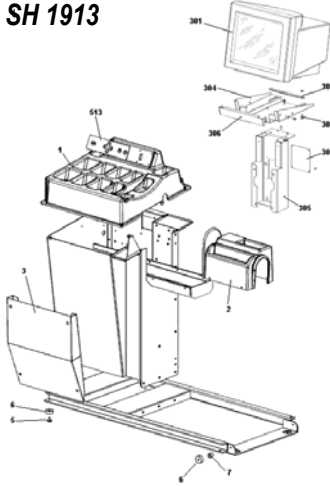

Pag. 360
Vol. 2°

Pag. 362
Vol. 2°

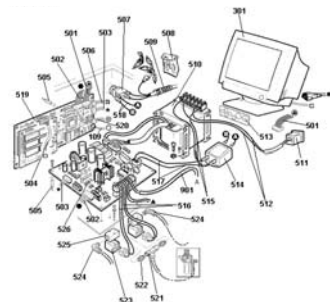

SH 1915

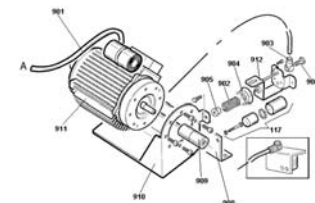
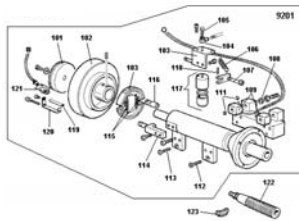

SH 1916

Pag. 363
Vol. 2°

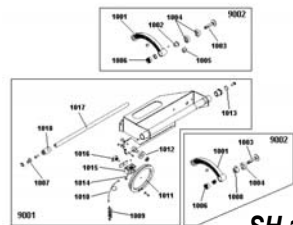

SH 1914

Pag. 361
Vol. 2°

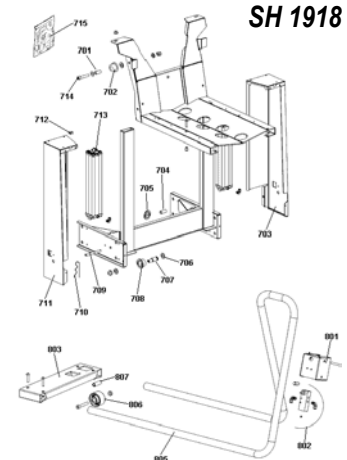

SH 1918

Pag. 365
Vol. 2°

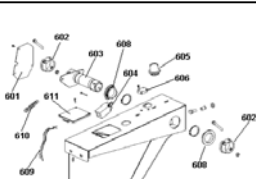

SH 1917

Pag. 364
Vol. 2°

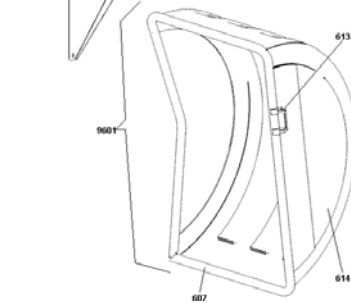

Pag. 366
Vol. 2°

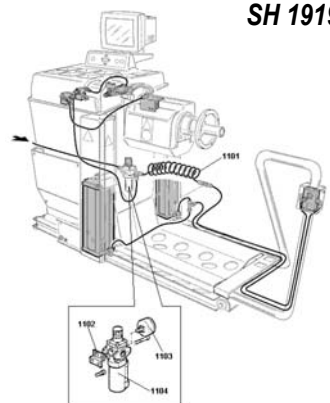

SH 1919

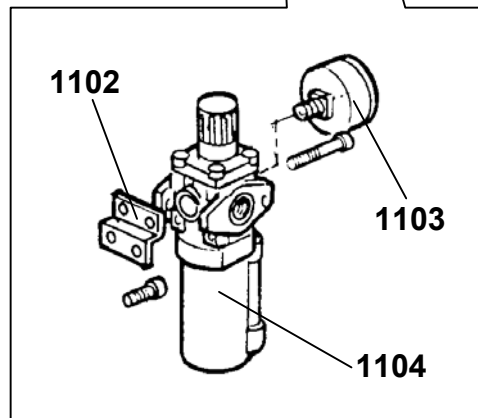
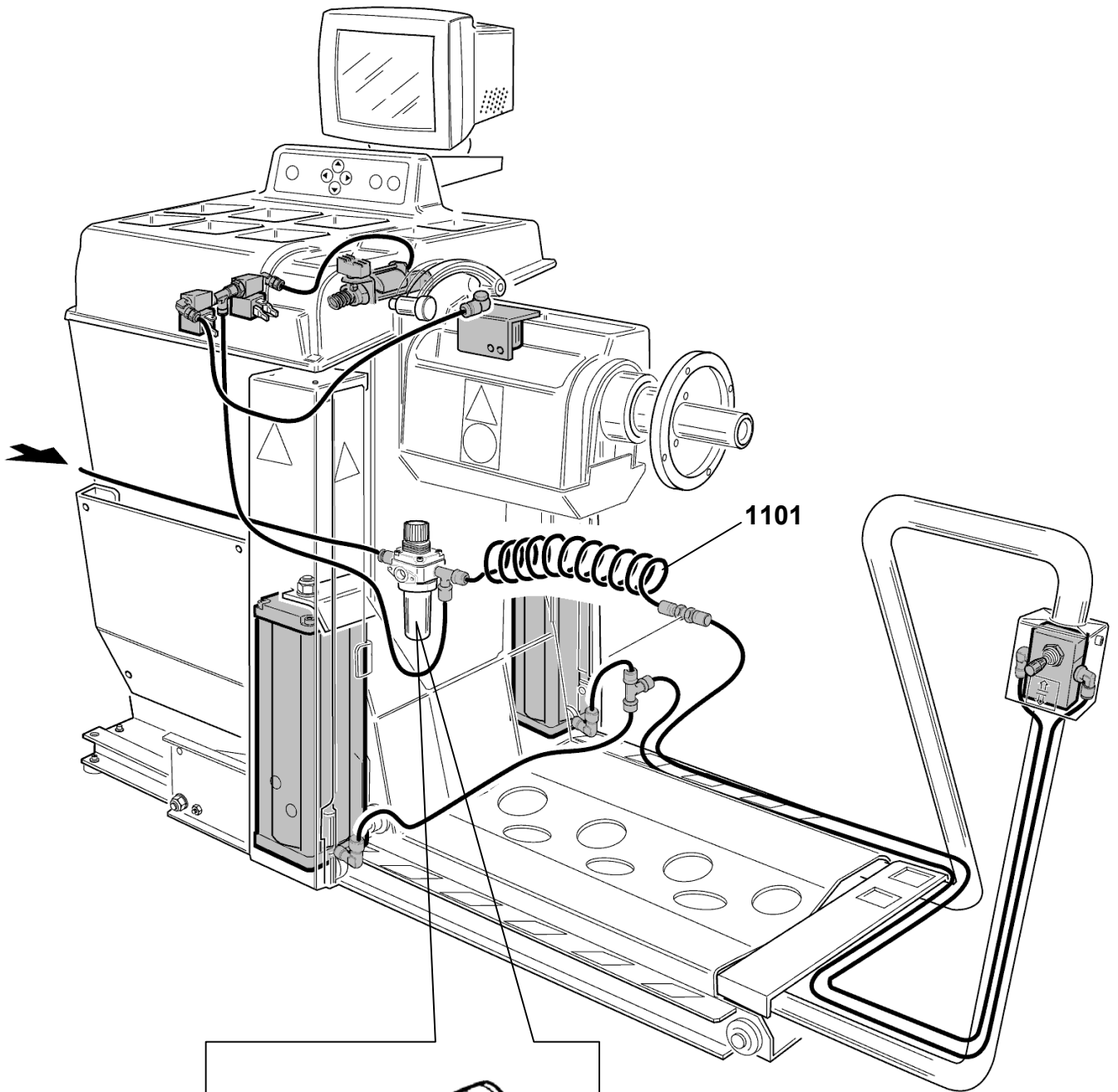

Codice Code	Pos.	Ricambi Descrizione	Spare parts Description	Pièces Détachées Désignation	Ersatzteile Beschreibung
701684		Tubo Rilsan nero D.6-4 (*)	Black Rilsan hose D.6-4 (*)	Tube en Rilsan noir D.6-4 (*)	Schwarz-Rislanschlauch D.6-4 (*)
459357	1101	Tubo spiralato L= 1500	Spiral hose L= 1500	Tube en spirale L= 1500	Spiralschlauch L= 1500
333683	1102	Staffa fissaggio filtro	Filter support bracket	Etrier de fixation du filtre	Filter-Befestigungsbügel
3-00488	1103	Manometro d. 40 12 BAR/PSI 1/8"	Pressure gauge d. 40 12 BAR/PSI 1/8"	Manomètre d. 40 12 BAR/PSI 1/8"	Druckmesser d. 40 mit 12 BAR-Anzeigeskala 1/8"
3-00314	1104	Filtro regolatore	Air conditioning unit	Filtre régulateur	Regelfilter
			<p>*: Il codice si riferisce all'unità di misura (1MT). Per la richiesta del ricambio specificare la la lunghezza desiderata.</p> <p>*: The code is referred to unit of length (1MT). For the request of spare part please specify the length you want.</p>		

N.B. I pezzi dentro ai riquadri sono normalmente disponibili a magazzino.

The parts in evidence are normally available from stock.

Les pièces détachées encadrées sont normalement disponibles en magasin.

Hinweis: Die umrahmten Teile sind in der Regel jederzeit lieferbar.

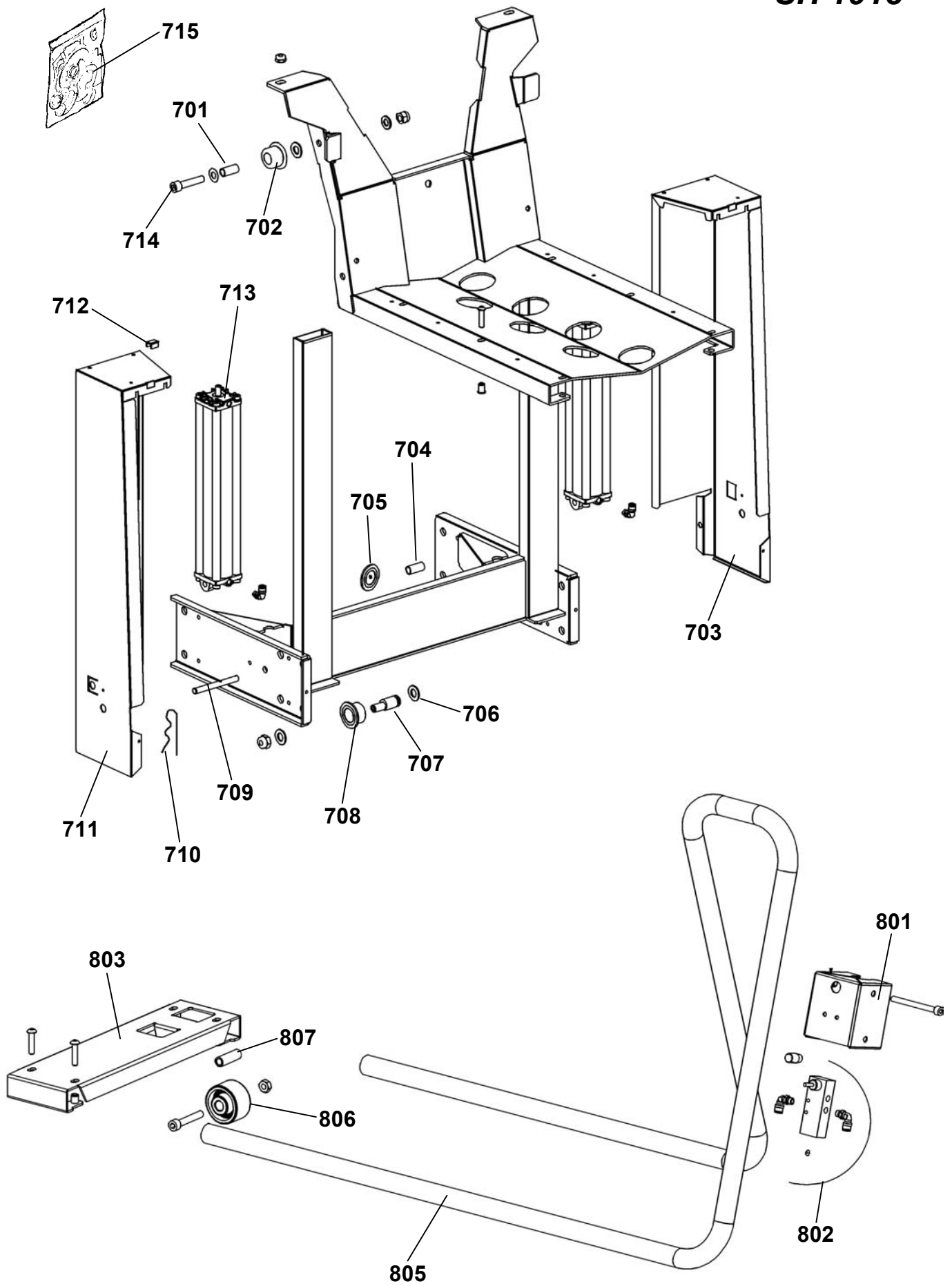

Codice Code	Pos.	Ricambi Descrizione	Spare parts Description	Pièces Détachées Désignation	Ersatzteile Beschreibung
344998	701	Distanziale rullo	<i>Roller spacer</i>	Entretoise pour rouleau	<i>Abstandstück für Rolle</i>
245879	702	Rotella con cuscinetto	<i>Wheel with bearing</i>	Roue avec coussinet	<i>Rad mit Lager</i>
358286	703	Carter DX	<i>Right casing</i>	Enveloppe droite	<i>Rechts-Gehäuse</i>
345817	704	Pattino semisferico	<i>Pad</i>	Patin	<i>Gleitschuh</i>
462932	705	Piedino in PVC	<i>PVC foot</i>	Pied en PVC	<i>PVC--Fuss</i>
454488	706	Anello OR d. 13,87 x 3,53	<i>O-Ring d. 13.87 x 3.53</i>	Bague OR d. 13,87 x 3,53	<i>O-Ring d. 13,87 x 3,53</i>
358283	707	Perno eccentrico	<i>Eccentric pin</i>	Pivot excentrique	<i>Exzenterzapfen</i>
258372	708	Rotella con cuscinetto	<i>Wheel with bearing</i>	Roue avec coussinet	<i>Rad mit Lager</i>
358282	709	Perno cilindro	<i>Cylinder pin</i>	Pivot pour cylindre	<i>Zapfen für Zylinder</i>
435055	710	Molla a spillo d. 2	<i>Sprind d. 2</i>	Ressort à pointeau d. 2	<i>Haarnadelfeder d. 2</i>
358285	711	Carter SX	<i>Left casing</i>	Enveloppe gauche	<i>Links-Gehäuse</i>
458293	712	Attacco pannello H. 4,2 - 5,1	<i>Connection H. 4.2 - 5.1</i>	Attaque H. 4,2 - 5,1	<i>Halterung H. 4,2 - 5,1</i>
258194	713	Cilindro d. 50	<i>Cylinder d. 50</i>	Vérin d. 50	<i>Zylinder d. 50</i>
358445	714	Perno rullo	<i>Roller pin</i>	Pivot pour rouleau	<i>Zapfen für Rolle</i>
261787	715	Kit guarnizioni	<i>Seal kit</i>	Kit joints	<i>Dichtungsgarnitur</i>
360999	801	Scatola porta valvola	<i>Box for valve</i>	Boîte pour supape	<i>Dose für Ventil</i>
244929	802	Valvola 1/8" 5/3 vie compl.	<i>Compl. 5/3-Way valve 1/8"</i>	Soupape 5/3 voies 1/8" compl.	<i>5/3-Wege-Ventil 1/8", kpl</i>
361001	803	Supporto ruota	<i>Wheel support</i>	Support pour roue	<i>Halterung für Rad</i>
361000	805	Manico sollevatore	<i>Handle</i>	Manche	<i>Stiel</i>
344955	806	Ruota D. 60 x 35	<i>Wheel D. 60 x 35</i>	Roue D. 60 x 35	<i>Rad D. 60 x 35</i>
344957	807	Perno forato	<i>Holed pin</i>	Pivot forée	<i>Zapfen</i>

N.B. I pezzi dentro ai riquadri sono normalmente disponibili a magazzino.

The parts in evidence are normally available from stock.

Les pièces détachées encadrées sont normalement disponibles en magasin.

Hinweis: Die umrahmten Teile sind in der Regel jederzeit lieferbar.

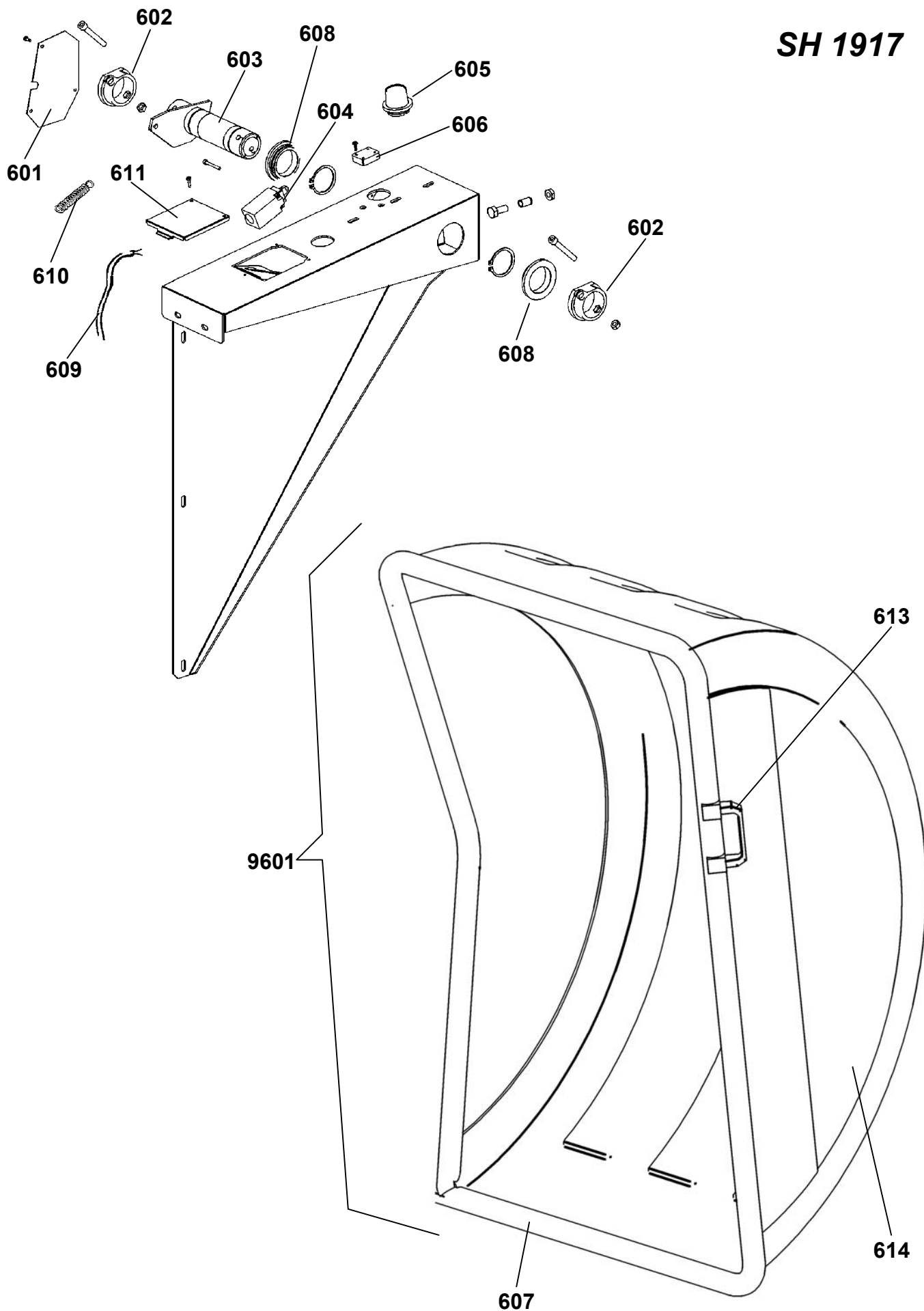

Codice Code	Pos.	Ricambi Descrizione	Spare parts Description	Pièces Détachées Désignation	Ersatzteile Beschreibung
358003	601	Piastra di chiusura	<i>Closing slab</i>	Plaque de fermeture	<i>Verschlussplatte</i>
446673	602	Boccola comando microinterruttore	<i>Switch control bush</i>	Douille commande microcontact	<i>Mikroschalter-Steuerbüchse</i>
258002	603	Camma protezione	<i>Guard cam</i>	Came pour protection	<i>Nocken für Radschutzbogen</i>
441494	604	Microinterruttore	<i>Microswitch</i>	Microinterrupteur	<i>Mikroschalter</i>
441224	605	Portaconi ad incastro	<i>Cones support</i>	Porte-cône à encastrement	<i>Konushalter, einspannbar</i>
427199	606	Tassello	<i>Small block</i>	Tampon	<i>Gummipuffer</i>
358130	607	Tubo per protezione	<i>Wheel guard frame</i>	Cadre pour protection	<i>Griffrohr für Radschutzbogen</i>
458005	608	Boccola	<i>Bushing</i>	Coquille	<i>Büchse</i>
240536	609	Cavo collegamento microinterruttore - START	<i>Microswitch-START connecting cable</i>	Câble raccordement microinterrupteur - START	<i>Anschlusskabel Mikroschalter - START</i>
440155	610	Molla d. 37 x 194 x 5	<i>Spring d. 37 x 194 x 5</i>	Ressort d. 37 x 194 x 5	<i>Feder d. 37 x 194 x 5</i>
358004	611	Lamiera di chiusura	<i>Closing lmetal sheet</i>	Tôle de fermeture	<i>Verschlussblech</i>
433473	613	Maniglia	<i>Handle</i>	Poignée	<i>Handgriff</i>
440482	614	Protezione ruota	<i>Wheel guard</i>	Protection roue	<i>Radschutzbogen</i>
260957	9601	Protezione ruota completa	<i>Complete wheel guard</i>	Protection roue complet	<i>Radschutzbogen, komplett</i>

N.B. I pezzi dentro ai riquadri sono normalmente disponibili a magazzino.

The parts in evidence are normally available from stock.

Les pièces détachées encadrées sont normalement disponibles en magasin.

Hinweis: Die umrahmten Teile sind in der Regel jederzeit lieferbar.

SH 1916

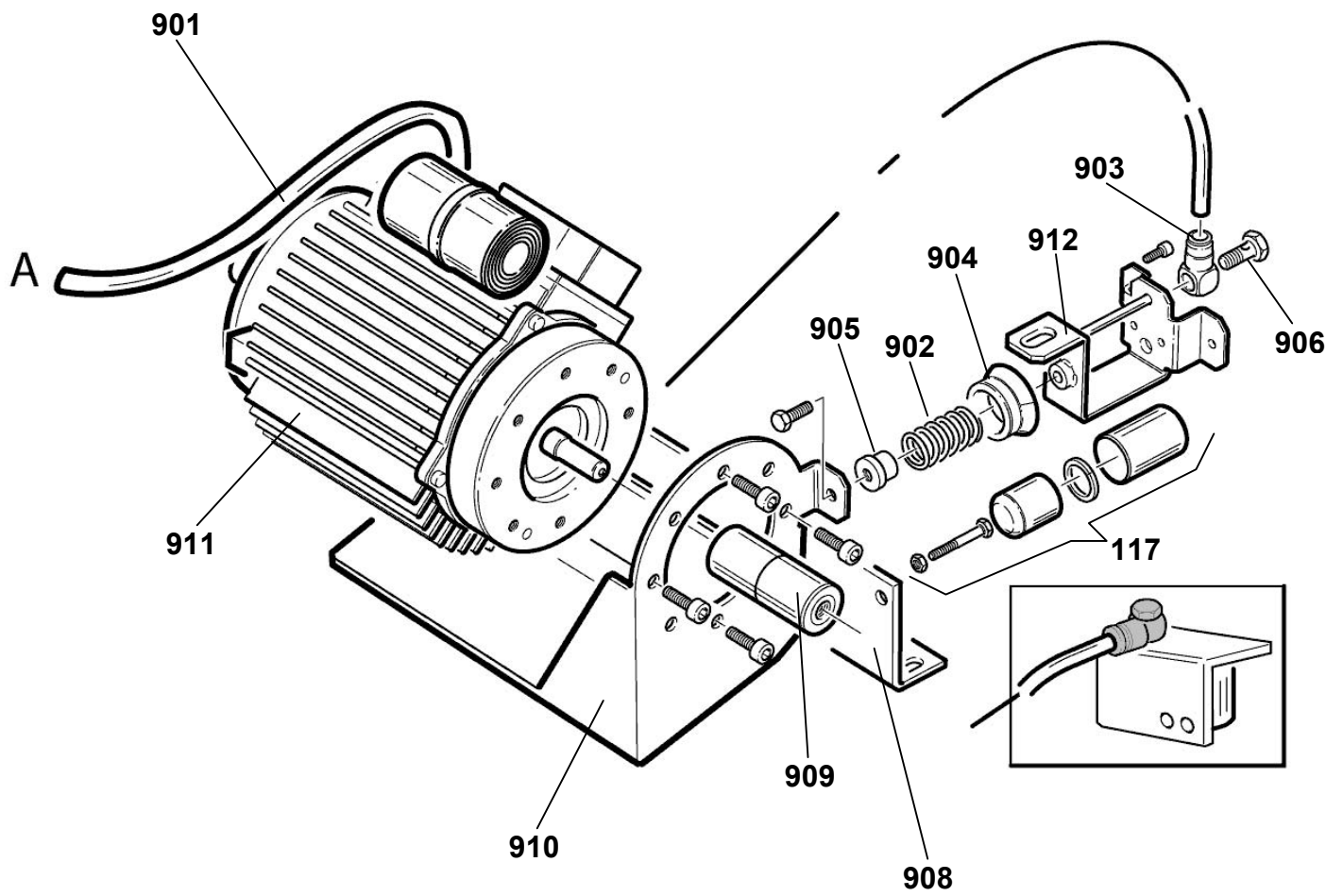

Codice Code	Pos.	Ricambi Descrizione	Spare parts Description	Pièces Détachées Désignation	Ersatzteile Beschreibung
244969	117	Cilindro completo	<i>Complete cylinder</i>	Vérin complet	Zylinder, kpl
458306	901	Cavo motore	<i>Motor cable</i>	Câble moteur	Kabel
453109	902	Molla	<i>Spring</i>	Ressort	Feder
246472	903	Raccordo orientabile corto + strozzatore 0,65	<i>Swinging union + throttle 0,65</i>	Raccord + etrangleur 0,65	Verbindungsstück mit Drossel 0,65
353111	904	Blocchetto mobile	<i>Moving block</i>	Bloc mobile	Möbelblock
353112	905	Blocchetto fisso	<i>Fixed block</i>	Bloc fixe	Festblock
3-00070	906	Vite cava singola M.5	<i>Special screw M.5</i>	Vis spécial M.5	Speziellchraube M.5
353110	908	Cerniera elastica	<i>Elastic hinge</i>	Charniere élastique	Elastik-Scharner
253134	909	Rullo di frizione	<i>Clutch roller</i>	Rouleau de friction	Walze
353107	910	Supporto motore	<i>Motor support</i>	Support moteur	Motorhalterung
453035	911	Motore 0.22 KW 230 V	<i>Motor 0.22 KW 230 V</i>	Moteur 0.22 KW 230 V	Motor 0.22 KW 230 V
453036	911	Motore 0.15 KW 115 V	<i>Motor 0.15 KW 110 V</i>	Moteur 0.15 KW 110 V	Motor 0.15 KW 110 V
253108	912	Supporto cilindro	<i>Cylinder support</i>	Support vérin	Zylinderhalterung

N.B. I pezzi dentro ai riquadri sono normalmente disponibili a magazzino.

The parts in evidence are normally available from stock.

Les pièces détachées encadrées sont normalement disponibles en magasin.

Hinweis: Die umrahmten Teile sind in der Regel jederzeit lieferbar.

SH 1915

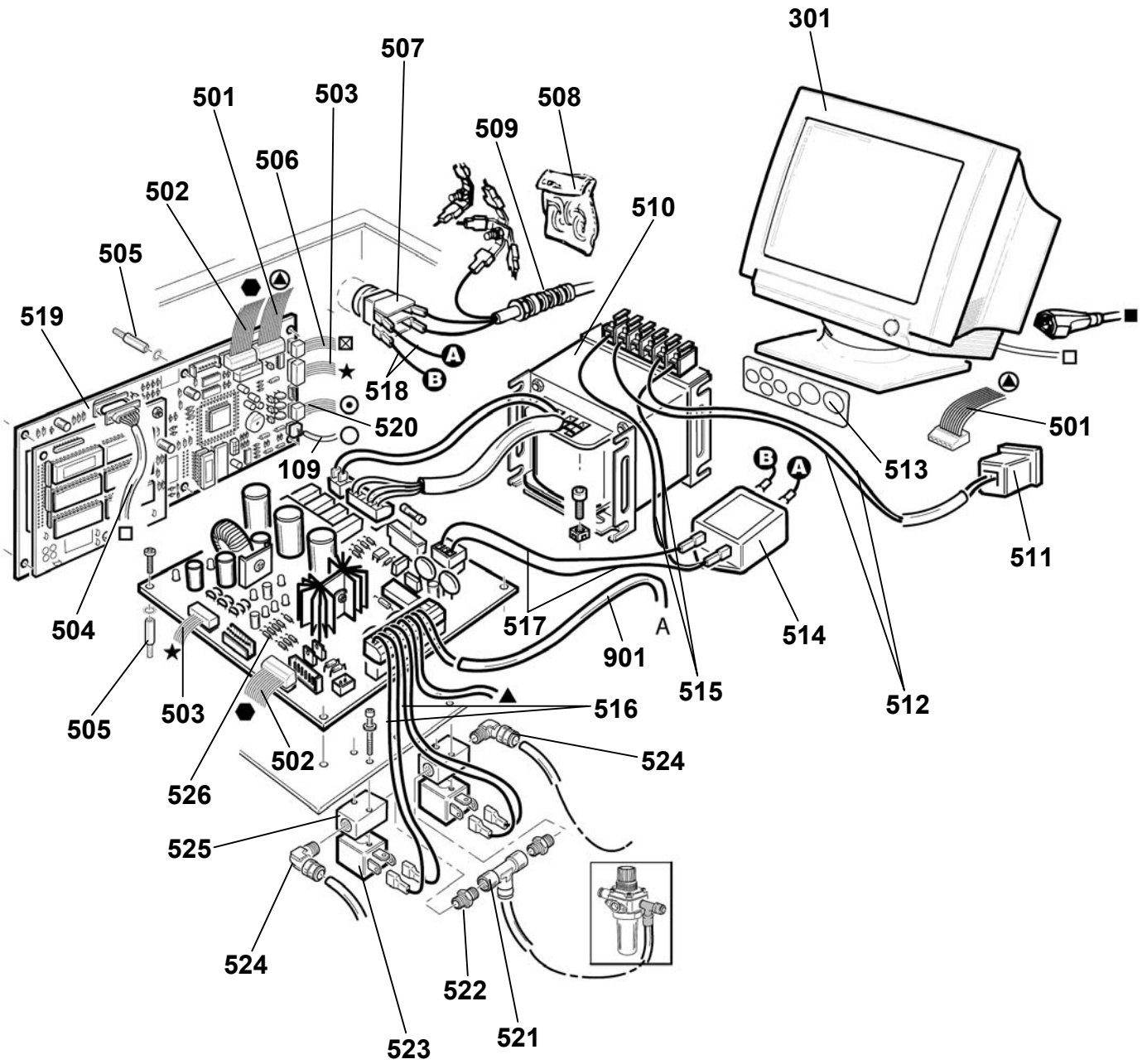

Codice Code	Pos.	Ricambi Descrizione	Spare parts Description	Pièces Détachées Désignation	Ersatzteile Beschreibung
246137	109	Pick-up + cavo di colleg.	Pick-up with cable	Pick-up avec câble	Pick-up mit Kabel
459379	301	Video a colori 15" SVGA	15" colour VDU	Ecran couleurs 15"	15" Farbbildschirm
448379	501	Cavo flat	Flat cable	Câble flat	Flacher Kabel
448376	502	Cavo flat	Flat cable	Câble flat	Flacher Kabel
458315	503	Cavo	Cable	Câble	Kabel
258316	504	Cavo monitor- SK MBC	Monitor-MBC board cable	Câble moniteur - Fiche MBC	Bildschirm-MBC Kabel
321020	505	Colonna distanziale	Stud spacer	Entretoise	Distanzhülse
458312	506	Cavo flat	Flat cable	Câble flat	Flacher Kabel
258309	507	Interruttore	Switch	Interrupteur	Schalter
244869	508	Sacchetto fusibili 0,1 AT	Bag of 0.1 AT fuses	Sachet fusibles 0,1 AT	Beutel mit 0,1 AT Sicher.
232942	508	Sacchetto fusibili 3,15 AT	Bag of 3.15 AT fuses	Sachet fusibles 3,15 AT	Beutel mit 3,15 AT Sicher.
216039	508	Sacchetto fusibili 1 A	Bag of 1 A fuses	Sachet fusibles 1 A	Beutel mit 1 A Sicher.
236665	508	Sacchetto fusibili 5 AT	Bag of 5 AT fuses	Sachet fusibles 5 AT	Beutel mit 5 AT Sicher.
255801	508	Sacchetto fusibili 10 A T	Bag of 10 A T fuses	Sachet fusibles 10 A T	Beutel mit 10 A T Sicher.
235392	509	Cavo rete	Power supply cable	Câble réseau	Speisekabel
438727	510	Trasformatore	Power supply transformer	Transformateur	Trafo
453965	511	Presca	Plug	Prise	Steckdose
445483	512	Cavo	Cable	Câble	Kabel
461105	513	Tastiera	Keyboard	Clavier	Tastatur
448914	514	Filtro rete	Power supply filter	Filtre réseau	Speisefilter
250323	515	Cavo	Cable	Câble	Kabel
258311	516	Cavo	Cable	Câble	Kabel
455684	518	Cavo	Cable	Câble	Kabel
263741	519	Scheda MBC 166 compl.	Complete MBC 166 board	Fiche MBC 166 complete	Platine MBC 166 Kpl
458314	520	Cavo flat	Flat cable	Câble flat	Flacher Kabel
3-00063	521	Raccordo a T 1/8"	T-Union 1/8"	Raccord à T 1/8"	T-Verbindung 1/8"
3-01146	522	Adattatore 6881-6 1/8"	Adapter 6881-6 1/8"	Adaptateur 6881-6 1/8"	Adapter 6881-6 1/8"
3-00413	523	Solenoido valvola	Solenoid	Solenoïde valve	Ventilsolenoid
3-00217	524	Raccordo a 90°	Union 90°	Raccord à 90°	Verbindung 90°
3-00414	525	Corpo elettrovalvola	Solenoid valve	Corps électrovalve	Magnetventilkörper
457674	526	Scheda alimentatore	Power board	Fiche alimentateur	Steuerplatine
458306	901	Cavo	Cable	Câble	Kabel

N.B. I pezzi dentro ai riquadri sono normalmente disponibili a magazzino.

The parts in evidence are normally available from stock.

Les pièces détachées encadrées sont normalement disponibles en magasin.

Hinweis: Die umrahmten Teile sind in der Regel jederzeit lieferbar.

Codice Code	Pos.	Ricambi Descrizione	Spare parts Description	Pièces Détachées Désignation	Ersatzteile Beschreibung
423170	101	Disco encoder	Encoder disk	Disque recherche	Suchplatte
353104	102	Puleggia interna	Pulley	Poulie	Riemenscheibe
439495	103	Ceppo freno	Brake block	Mâchoire de frein	Bremsbacke
246472	104	Raccordo orientabile corto + strozzatore 0,65	Swinging union + throttle 0,65	Raccord + étrangleur 0,65	Verbindungsstück mit Drossel 0,65
3-00070	105	Vite cava singola lunga M 5	Special screw M 5	Vis spécial M 5	Speziellschraube M 5
432335	106	Molla d. 9 x 54	Spring d. 9 x 54	Ressort d. 9 x 54	Feder d. 9 x 54
241386	107	Leva freno	Brake lever	Levier frein	Hebelbremse
424993	108	Molla a tazza d. 10,2 x 22 x 1,2	Belleville washer d. 10,2 x 22 x 1,2	Ressort à godet d. 10,2 x 22 x 1,2	Tellerfeder d. 10,2 x 22 x 1,2
246137	109	Coppia pick-up + cavo	Pair of pick-up + cable	Couple pick-up avec câble	Pick-up paar + Kabel
439493	110	Molla a spillo d. 2	Spring d. 2	Ressort à pointeau d. 2	Haarnadelfeder d. 2
2-00243	111	Sfera SKF-RB 7,938/T205 5/16"	5/16" Steel ball SKF-RB 7,938/T205	Bille SKF-RB 7,938/T205 5/16"	Stahlkugel SKF-RB 7,938/T205 5/16"
339431	112	Vite svasata M 8 x 35	Screw M 8 x 35	Vis M 8 x 35	Schraube M 8 x 35
339430	113	Vite svasata M 8 x 20	Screw M 8 x 20	Vis M 8 x 20	Schraube M 8 x 20
339269	114	Attacco fulcro	Fulcrum attachment	Fixation pivot	Drehpunkt-Anschluß
439494	115	Molla per freno d. 8,8 x 46 x 2	Brake spring d. 8,8 x 46 x 2	Ressort pour frein d.8,8x46x2	Bremsfeder d. 8,8 x 46 x 2
339271	116	Blocchetto	Block	Bloc	Block
244969	117	Cilindro	Cylinder	Vérin	Zylinder
239273	118	Supporto pistone	Piston support	Support pour piston	Kolbenhalter
351586	119	Distanziale	Spacer	Entretoise	Distanzstück
351574	120	Supporto scheda ricerca	Encoder board support	Support carte recherche	Suchplatinenhalterung
249280	121	Gruppo ricerca	Encoder assembly	Groupe recherche	Suchgruppe
238304	122	Mozzo filettato + estraattore	Threaded hub + extractor	Moyeu fileté + extracteur	Gewindenabe + Ausziehvorrichtung
430573	123	Peso 100 gr.	100 g. weight	Poids 100 g.	Gewicht 100 g.
439516	123	Peso 300 gr.	300 g. weight	Poids 300 g.	Gewicht 300 g.
458033	1001	Braccio rilevatore	Gauge arm	Bras capteur	Fühler-Arm
359358	1002	Boccola fissa	Bushing	Douille	Buchse
458260	1003	Terminale mobile	Terminal	Cosse	Endverschluss
458261	1004	Pulsante portapesi	Button	Bouton	Duckknopf
459041	1005	Molla in gomma	Rubber spring	Ressort en caoutchouc	Gummifeder
363646	1006	Manopola portapesi corta STD	STD Short knob	Poignée courte STD	Ballengriff STD
458262	1006	Manopola portapesi GERM.			Ballengriff "DEUTSCHL."
458259	1007	Gancio fune	Cable hook	Crochet pour câble	Haken für seil
458259	1008	Terminale fisso	Terminal	Cosse	Endverschluss
457598	1009	Molla d. 16 x 45 x 0,8	Spring d. 16 x 45 x 0,8	Ressort d. 16 x 45 x 0,8	Feder d. 16 x 45 x 0,8
457941	1010	Fune di trascinamento	Cable	Câble	Seil
358023	1011	Puleggia d. 136	Pulley d.136	Poulie d. 136	Riemenscheibe d. 136
358026	1012	Puleggia di rinvio	Pulley	Poulie	Riemenscheibe
449335	1013	Guarnizione d. 15,47 x 3,53	Seal d. 15.47 x 3.53	Joint d. 15,47 x 3,53	Dichtung d. 15,47 x 3,53
457479	1014	Anello elastico D. 18	Ring	Anneau	Ring
457404	1015	Supporto puleggia	Pulley support	Support poulie	Riemenscheibehalterung
248387	1016	Potenziometro	Potentiometer	Potentiometre	Potentiometer
357405	1017	Asta rilevatore	Sensor rod	Tige capteur	Fühler-Stab
357752	1018	Boccola scorrimento int.	Bushing	Douille	Buchse
258018	9001	Gruppo rilevatore	Gauge assembly	Groupe capteur	Aufnehmer-Gruppe
258195	9002	Braccio rilevatore STD	STD gauge arm	Bras capteur STD	Fühler-Arm, STD
258677	9002	Braccio rilevatore GERMANIA			Fühler-Arm, DEUTSCHLAND
253105	9201	Gruppo oscillante completo	Complete shaft assembly	Groupe oscillant complet	Maschinenwelle, komplett

N.B. I pezzi dentro ai riquadri sono normalmente disponibili a magazzino.

The parts in evidence are normally available from stock.

Les pièces détachées encadrées sont normalement disponibles en magasin.

Hinweis: Die umrahmten Teile sind in der Regel jederzeit lieferbar.

SH 1913

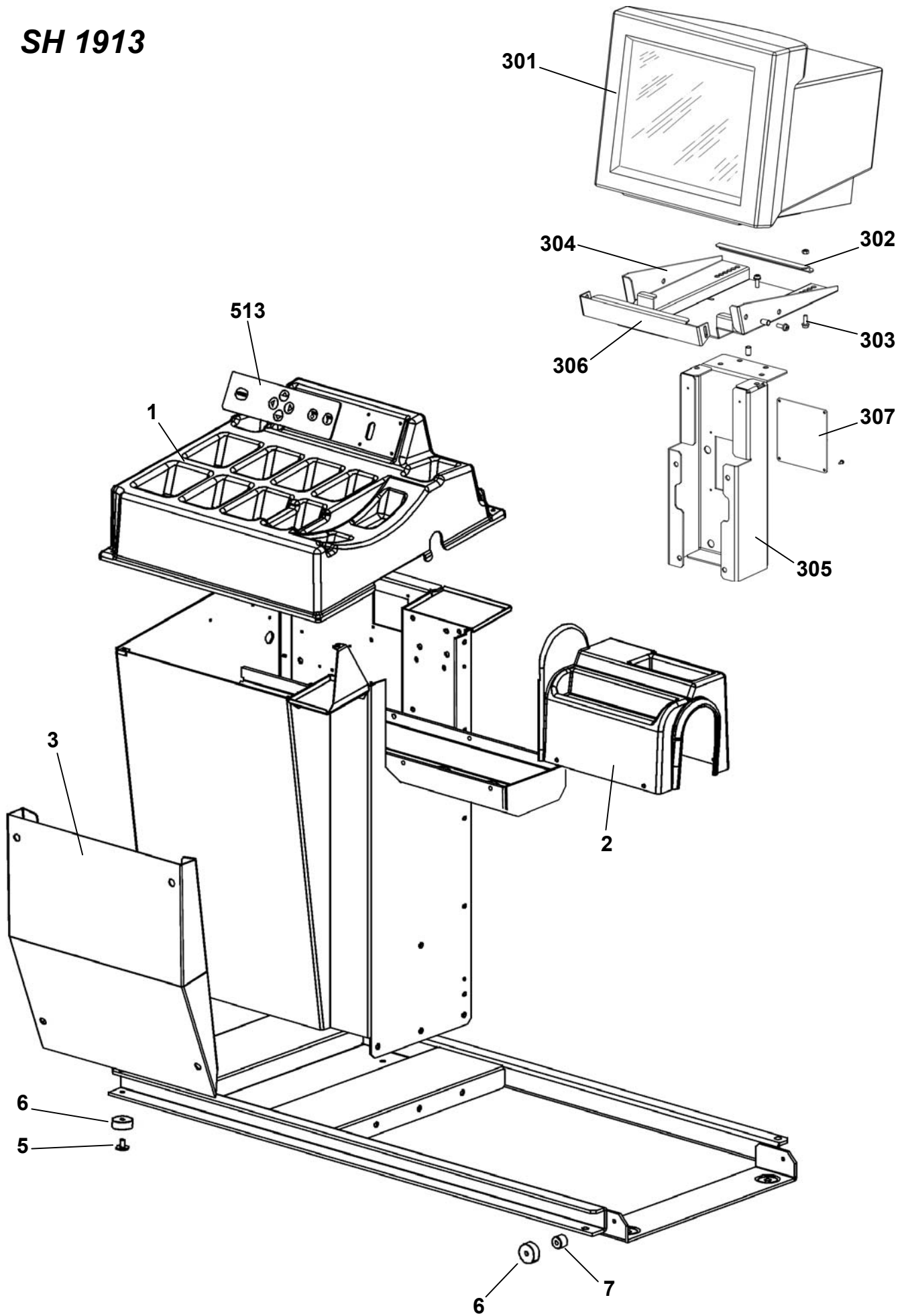

Codice Code	Pos.	Ricambi Descrizione	Spare parts Description	Pièces Détachées Désignation	Ersatzteile Beschreibung
461106	1	Coperchio portapesi	<i>Weight storage deck</i>	Plan porte-masses	<i>Behälter für Gewichte</i>
458044	2	Protezione gruppo oscillante	<i>Shaft assembly guard</i>	Protection pour groupe oscillant	<i>Schwenkeinheits-Schutz</i>
361100	3	Cofano anteriore	<i>Front crank case</i>	Enveloppe avant	<i>Vordere Maschinenabdeckung</i>
353539	5	Distanziale esagonale	<i>Spacer</i>	Entretoise	<i>Distanzstück</i>
427291	6	Piede	<i>Foot</i>	Pied	<i>Fuss</i>
358009	7	Distanziale fermo	<i>Spacer</i>	Entretoise	<i>Distanzstück</i>
459379	301	Video a colori 15" SVGA	<i>15" colour VDU</i>	Ecran couleurs 15"	<i>15" Farbbildschirm</i>
356992	302	Staffa bloccaggio post.	<i>Rear locking bracket</i>	Etrier de blocage posterieure	<i>Hinterer Blokierungklaue</i>
456859	303	Vite con collare	<i>Screw</i>	Vis	<i>Schraube</i>
356927	304	Supporto testata	<i>VDU basement</i>	Base pour écran	<i>Monitorbasis</i>
368852	305	Supporto monitor	<i>VDU support</i>	Support pour écran	<i>Monitorhalterung</i>
357733	306	Staffa bloccaggio ant.	<i>Front locking bracket</i>	Etrier de blocage anterieure	<i>Vorderer Blokierungklaue</i>
360993	307	Coperchio posteriore	<i>Rear cover</i>	Couvercle arriere	<i>Hintere Abdeckung</i>
461105	513	Tastiera	<i>Keyboard</i>	Clavier	<i>Tastatur</i>

N.B. I pezzi dentro ai riquadri sono normalmente disponibili a magazzino.

The parts in evidence are normally available from stock.

Les pièces détachées encadrées sont normalement disponibles en magasin.

Hinweis: Die umrahmten Teile sind in der Regel jederzeit lieferbar.